

Simply a question of
better measurement



SCHMIDT[®] Flow Sensor
SS 20.600
Instructions for Use

SCHMIDT® Flow Sensor SS 20.600

Table of Contents

1	Important information.....	3
2	Application range.....	4
3	Mounting instructions.....	7
4	Electrical connection.....	20
5	Signaling.....	25
6	Commissioning.....	30
7	Information concerning operation.....	31
8	Service information.....	32
9	Dimensions.....	36
10	Technical data.....	37
11	Declarations of conformity.....	39

Imprint:

Copyright 2022 **SCHMIDT Technology GmbH**

All rights reserved

Version: 535084.02D

Subject to modifications

1 Important information

The instructions for use contain all required information for a fast commissioning and a safe operation of **SCHMIDT®** flow sensors.

- These instructions for use must be read completely and observed carefully, before putting the unit into operation.
- Any claims under the manufacturer's liability for damage resulting from non-observance or non-compliance with these instructions will become void.
- Tampering with the device in any way whatsoever - with the exception of the designated use and the operations described in these instructions for use - will forfeit any warranty and exclude any liability.
- The unit is designed exclusively for the use described below (refer to chapter 2). In particular, it is not designed for direct or indirect protection of personal or machinery.
- **SCHMIDT Technology** cannot give any warranty as to its suitability for a certain purpose and cannot be held liable for errors contained in these instructions for use or for accidental or sequential damage in connection with the delivery, performance or use of this unit.

Symbols used in this manual

The symbols used in this manual are explained in the following section.



Danger warnings and safety instructions. Read carefully!

Non-observance of these instructions may lead to injury of personal or malfunction of the device.

General note

All dimensions are given in mm.

2 Application range

The **SCHMIDT® Flow Sensor SS 20.600** (art. no.: 524 600) is designed for stationary measurement of the flow velocity as well as the temperature of pure¹ air and gas with operating temperature up to 120 °C and working pressure² up to 40 bar.

The sensor is based on the measuring principle of a thermal anemometer and measures the mass flow of the measuring medium as flow velocity which is output in a linear way as standard velocity³ w_N (unit: m/s), based on standard conditions of 1013.25 hPa and 20 °C. Thus, the resulting output signal is independent of the pressure and temperature of the medium to be measured.



When using the sensor outdoors, it must be protected against direct exposure to the weather.



If the sensor head is immersed in water and operated under pressure, the sensor may be damaged irreversibly.



Using the sensor in flammable gases the regulations of ATEX guideline has to be applied (see below).



The sensor variants for use in potentially explosive atmosphere (ATEX) and oxygen (O₂) are not combinable.

Version ATEX

The ATEX version of the sensor is designed for use in explosive gas atmosphere of zone 2 (corresponding to EPL Gc) and explosive dust atmosphere of zone 22 (corresponding to EPL Dc).

ATEX-specific information can be found in the “Supplementary instructions for use in explosive atmospheres ATEX”.



The additional **ATEX instructions** (535698.02) must be read and observed carefully when using the sensor in ATEX areas.



The operation in continuously or frequently occurring explosive atmosphere is not allowed.

¹ No chemically aggressive contents /abrasive particles; check suitability in individual cases

² Overpressure

³ Corresponds to the actual velocity under standard conditions

Version Oxygen (O₂)

The optional "oxygen" version can be used in gas mixtures with an oxygen fraction of more than 21 % or pure oxygen.

The adaptations comprise:

- Use of oxygen-compatible sealing material (BAM approval) and lubricant in compression fitting.
- Special cleaning of the sensor, its accessories and packaging according to the standard IEC/TR 60877:1999.

This standard may be restricted by:

- Special conditions regarding the use of diatomic oxygen (O₂).
- The operating specifications of the **SS 20.600** with regard to:
 - Maximum overpressure of the medium of **20 bar**.
 - Maximum temperature of the medium of **60 °C**.



Exceeding these limits may result in danger to persons and material.

Information concerning the compliant handling of O₂



Improper handling of gas mixtures with an oxygen content of more than 21 % or pure oxygen can lead to fires or explosions.



It is explicitly pointed out that the customer, when opening the packaging, assumes full responsibility for cleanliness of sensor and its accessories according to standard IEC/TR 60877:1999.

As a general rule, it is essential to avoid contamination of those parts of the sensor that come into contact with oxygen:

- Carefully clean the installation site before mounting the sensor.
- Make sure to use only clean tools and material for installation.
- Before opening the packaging film, remove any dirt such as dust from its surface, if necessary.
- If possible, wait until you are at the installation site before opening the packaging to take out the sensor.
- Otherwise open the packaging film at an appropriate and clean workplace and store the sensor in an appropriate, cleaned, dust- and humidity-tight container.
- Do not touch the oxygen contacting sensor parts with bare hands.
- Use clean, non-fluffy gloves or cloths or similar to handle the sensor.

Version Special gases

The “Special gas” version of the **SS 20.600** is equipped with a correction for the measurement of certain gases and gas mixtures.

The sensor is adjusted and calibrated in air. Then a special correction for the medium to be measured is applied to the sensor. Those corrections have been determined for many gases in real gas ducts.

For gas mixtures, the correction is calculated according to the set volumic mixing ratio.



The customer is responsible for the observance of all relevant statutory provisions, standards and directives relating to the use of gases.

Version Parylene

This option has an increased media resistance.

The corresponding adjustments comprise:

- The entire sensor head (including its flow guiding chamber) is made of stainless steel (1.4571).
- Only the sensor head is coated with Parylene (see Figure 2-1).

The coating covers the entire sensor head, including the sensor chip within the flow chamber, up to just

before the assembly gap that results from the press fitting of the head into the probe's tube.

- The fitting zone inside the tube is sealed by two O-rings made of media-resistant FKM.

The specific suitability for the application is to be checked by the customer himself.

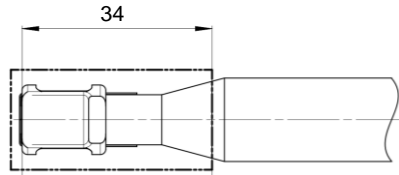

Figure 2-1

Mechanical versions

The sensor **SS 20.600** is available in the following basic designs:

- Compact sensor:
The sensor probe is mechanically fixed at the main enclosure.
- Remote sensor:
The sensor probe is connected to the main enclosure via an electrical cable.

The designs and their dimensions can be obtained from the dimensional drawings in chapter 9.

For ordering options (probe and cable lengths) see table 9 or the product brochure.

3 Mounting instructions

General information on handling

The flow sensor **SS 20.600** is a precision instrument with high measuring sensitivity. In spite of the robust construction of the sensor head, soiling of the inner sensor element can lead to distortion of measurement results (see also chapter 8 *Service information*).

During procedures like transport, mounting or dismounting of the sensor that facilitates soiling, it is generally necessary to attach the enclosed protective cap of **SCHMIDT Technology** to the sensor head and remove it only during operation.



During processes with risk of soiling such as transport or mounting, the protective cap should be placed on the sensor head.

Mounting method

The sensor **SS 20.600** can be mounted only by means of a compression fitting which supports the sensor tube and ensures positive clamping. The compression fitting as well as a pressure protection kit is included in the scope of delivery.

Due to the variety of applications the compression fitting exhibits different versions which share the following features:

- Pressure range: 40 bar (overpressure)
- Media temperature: Min. -20 ... +120 °C
- Material: Screw fittings made of stainless steel 1.4571
Clamping ring made of VA steel

Variations are made on one hand by the design of the outer screw thread (order option: G½ or R½) and on the other hand by materials and properties of the used O-seals:

- Standard: NBR (operating parameters see above)
- Oxygen (O₂): FKM (BAM approval)
- ATEX: FKM (suitable from -40 °C)

Systems with overpressure

Depending on the ordered version, the **SS 20.600** is designed for a maximum working overpressure of 16 bar (standard) or 40 bar (option).

As long as the medium to be measured is operated with overpressure, make sure that:

- There is no overpressure in the system during mounting.



Mounting and dismantling of the sensor can be carried out only as long as the system is **in a depressurized state**.

- Only suitable pressure-tight mounting accessories are used.
- Appropriate safety measures are installed to avoid unintended discarding of the sensor due to overpressure.



For measurements in media with overpressure, appropriate safety measures must be taken to prevent unintended discarding of the sensor.

If other accessories than the delivered pressure protection kit or alternative mounting solutions are used, the customer must ensure appropriate safety measures.



The pressure-tight mounting, the fastening of the screw pipe connection and the discarding protection must be checked before pressure is applied. These tightness checks must be repeated at reasonable intervals.



The components of the pressure protection kit (bolt, chain and bracket) have to be checked regularly for integrity.

Thermal boundary conditions

In the case of medium temperatures that exceed or fall below the permissible ambient temperatures of the electronics, cross-talk of the temperature into the electronics housing must be prevented by a cooling or warming-up distance of the sensor tube of at least 50 mm (see Figure 3-1) or other suitable measures.

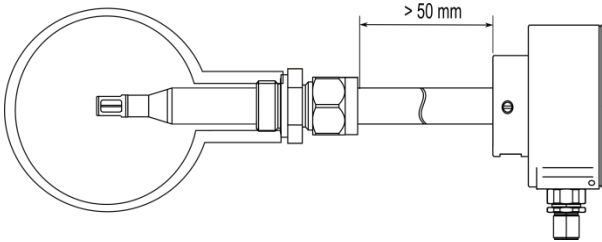

Figure 3-1



The permissible operating temperature range of the electronics must not be exceeded by crosstalk of the medium temperature on the sensor housing.

Flow characteristics

Local turbulences of the medium can cause distortion of measurement results. Therefore, appropriate mounting conditions must be guaranteed to ensure that the gas flow is supplied to the sensor in a laminar⁴, i.e. quiet and low in turbulence, state. The corresponding measures depend on the system properties (pipe, chamber, etc.) which are described in the following subchapters for different mounting variants.



Correct measurements require a (laminar) flow low in turbulence.

⁴ The term "laminar" means here an air flow low in turbulence (not according to its physical definition saying that the Reynolds number is < 2300).

General installation conditions

The sensor head of the **SS 20.600** consists of two basic elements:

- The enclosing measuring chamber:

The measuring chamber, also referred to as chamber head, protects the inner sensor chip from mechanical and electrical influences.

The aerodynamically optimized design allows tilting around the longitudinal axis of the sensor up to $\pm 3^\circ$ relative to the ideal measuring direction (see Figure 3-2) without significant impact on the measurement result⁵.



The axial tilting of the sensor head relative to the flow direction should not exceed $\pm 3^\circ$.

The center of the chamber head (also used for specification of probe length L) is the actual measuring point of the flow measurement and must be placed in the flow as advantageous as possible, for example in the middle of the pipe.



Position the sensor head always at the most advantageous position for flow measurement.

- The sensor chip:

The measurement direction is clearly defined by the measuring principle (unidirectional).

The measuring direction is indicated by means of two arrows; the first indication is located on the front of the chamber head, the other one is printed on the housing cover below the LED indication (see Figure 3-2). With the remote version, an additional arrow is located at the cable end of the sensor.

Note:

If the sensor has been mounted in the wrong direction (rotated by 180° relative to the flow direction) and flow is available, it does not output zero but wrong (too high) measuring values.



The sensor measures unidirectional and must be adjusted correctly relative to the flow direction.

⁵ Deviation < 1 % of the measured value

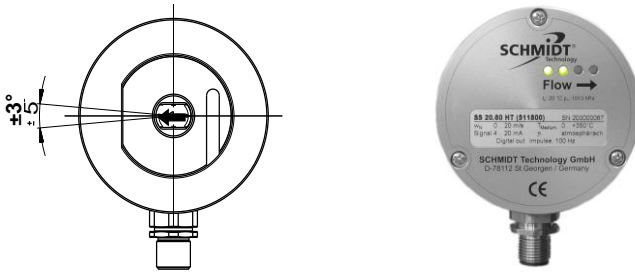

Figure 3-2 Arrangement of flow direction arrows

The design of the sensor element results in a minimal coupling between heater and medium temperature sensor, leading to a thermal crosstalk at minimal flow velocity near zero that defines the lower limit of the measuring range.



Due to system characteristics the lower measuring range limit of the sensor is 0.2 m/s.

Under unfavourable installation conditions, free convection may increase the crosstalk between heater and temperature element on the sensor chip and therefore the lower detection limit:

Measurements in a downward flow (downdraft flow, see Figure 3-3) lead to considerably increased measuring values in the lower flow range.

The area concerned depends on the system pressure. Correct measuring values are displayed above⁶ 2 m/s.

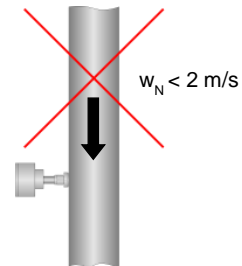

Figure 3-3



Avoid installation in a pipe or chamber with downward flow because the lower measuring range limit can rise significantly.

⁶ In case of a vertical downdraft flow and an overpressure of 16 bar.

Mounting in pipes with circular cross-section

Typical applications for this type are compressed air networks or burner gas supply lines. They are characterized by long thin pipes with a quasi-parabolic flow profile.

The easiest method to achieve a low-turbulence flow is to provide a sufficiently long and absolutely straight distance without disturbances (such as edges, seams, bends etc.) in front (run-in) and behind the sensor (run-out) (see installation drawing Figure 3-4). It is also necessary to pay attention to the design of the run-out distance because the flow is also influenced by disturbances generating turbulences against the flow direction.

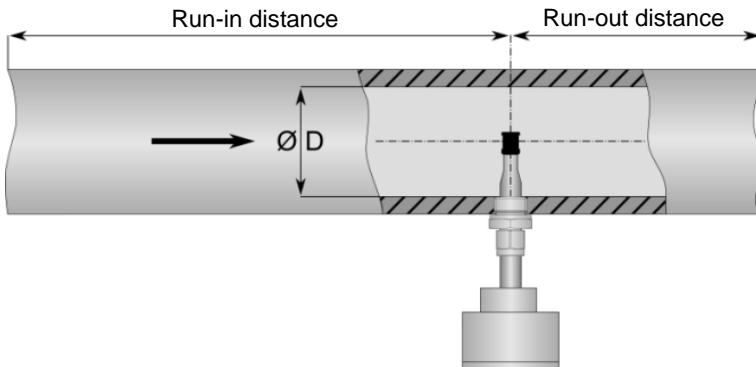

Figure 3-4

- L1 Length of run-in distance
- L2 Length of run-out distance
- D Inner diameter of measuring distance

The absolute length of the corresponding distances is defined by the inner diameter of the pipe because the flow abatement depends directly on the aspect ratio of measuring distance and diameter. Therefore, the required abatement distances are specified as a multiple of the pipe diameter D . Besides, the degree of turbulence generation by the corresponding disturbing object plays an important role. A slightly curved bend directs the air with a relative low-disturbance level, whereas a valve generates massive turbulences with its abrupt change of the flow-guiding cross-section that require a relatively long distance for abatement.

The following Table 1 shows the required straight pipe lengths depending on the inner tube diameter D and different causes of disturbances.

This table lists the minimum values required in each case. If the listed straight pipe lengths cannot be achieved, measurement accuracy may be impaired or additional actions are required like the use of flow rectifiers⁷.

⁷ E.g., honeycombs made of plastic or ceramics.

Flow obstacle upstream of measuring distance		Minimum distance length of	
		Run-in (L1)	Run-out (L2)
Light bend (< 90°)		10 x D	5 x D
Reduction Expansion 90° bend T-junction		15 x D	5 x D
Two 90° bends in one plane (2-dimensional)		20 x D	5 x D
Two 90° bends with 3-dimensional change in direction		35 x D	5 x D
Shut-off valve		45 x D	5 x D

Table 1 Run-in and run-out distances

The profile factors specified in Table 2 may become void by the use of flow rectifiers.

Calculation of volume flow

A quasi-parabolic speed profile is formed over the pipe's cross-section under laminar conditions. Whereas the flow velocity at the pipe walls remains almost zero, in the middle of the pipe it reaches the optimum measuring point, its maximum w_N .

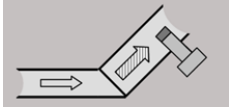
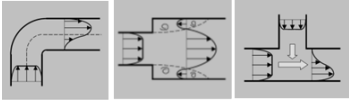
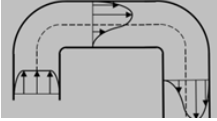
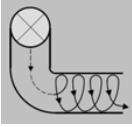
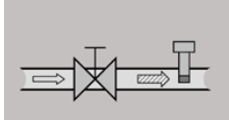
This measured variable can be converted into an average flow velocity $\overline{w_N}$ that is constant over the pipe cross-section with the aid of a correction factor the so-called profile factor.

The profile factor PF depends on the inner pipe diameter⁸ D and is shown in Table 2.

PF	Pipe Ø		Volume flow [m³/h]						
	Inner [mm]	Outer [mm]	Min. @	@ Sensor measuring range					
			0.2 m/s	10 m/s	20 m/s	60 m/s	90 m/s	140 m/s	220 m/s
0.796	26.0	31.2	0.3	15.2	30.4	91.3	136.9	213.0	334.7
0.748	39.3	44.5	0.7	32.7	65.3	196.0	294.0	457.3	718.6
0.772	51.2	57.0	1.1	57.2	114.4	343.3	515.0	801.1	1258
0.786	70.3	76.1	2.2	109.8	219.7	659.0	988.5	1537	2416
0.797	82.5	88.9	3.1	153.4	306.8	920.3	1380	2147	3374
0.804	100.8	108.0	4.6	231.0	462.0	1385	2078	3233	5081
0.812	125.0	133.0	7.2	358.7	717.5	2152	3228	5022	7892
0.817	150.0	159.0	10.4	519.8	1039	3118	4677	7276	11434
0.829	206.5	219.1	20.0	999.5	1999	5997	8995	13993	21989
0.835	260.4	273.0	32.0	1600	3201	9605	14408	22412	35219
0.840	309.7	323.9	45.6	2278	4556	13668	20502	31892	50116
0.841	339.6	345.6	54.8	2742	5484	16454	24681	38393	60331
0.845	388.8	406.4	72.2	3611	7223	21669	32504	50562	79455
0.847	437.0	457.0	91.5	4573	9146	27440	41160	64027	100614
0.850	486.0	508.0	113.5	5676	11353	34059	51088	79471	124883
0.852	534.0	559.0	137.4	6869	13738	41216	61824	96170	151125
0.854	585.0	610.0	165.3	8263	16526	49580	74371	115688	181796
0.860	800.0		311.2	15562	31124	93373	140059	217870	342368
0.864	1000		488.6	24429	48858	146574	219861	342006	537438
0.872	1500		1109	55474	110948	332845	499268	776639	1220433
0.877	2000		1983	99186	198372	595118	892677	1388609	2182100

Table 2 Profile factors and volume flows

⁸ Both inner air friction and sensor locking are responsible.

Thus, it is possible to calculate the standard volume flow of the medium using the measured standard flow velocity in a pipe with known inner diameter:

$A = \frac{\pi}{4} \cdot D^2$	D Inner diameter of pipe [m]
$\bar{w}_N = PF \cdot w_N$	A Cross-section area of pipe [m ²]
$\dot{V}_N = \bar{w}_N \cdot A$	w_N Flow velocity in the middle of the pipe [m/s]
	\bar{w}_N Average flow velocity in the pipe [m/s]
	PF Profile factor (for pipes with a circular cross-section)
	\dot{V}_N Standard volume flow [m ³ /s]

SCHMIDT Technology provides a "flow calculator" on its homepage for the calculation of flow velocity or volume flow in (circular) pipes or (rectangular) shafts for different sensor types:

www.schmidt-sensors.com or www.schmidttechnology.de

Installation in systems with square cross-section

For most applications, two limit cases can be distinguished with regard to flow conditions:

- Quasi-uniform flow field

The lateral dimensions of the flow-guiding system are approximately as large as its length in the flow direction and the flow velocity is small so that a stable trapezoidal⁹ speed profile of the flow is formed. The width of the flow gradient zone at the wall is negligible in relation to the chamber width so that a constant flow velocity can be expected over the whole chamber cross-section (the profile factor is in this case 1). The sensor must be mounted here in such a way that its sensor head is far enough from the wall and it measures in the area with the constant flow field.

Typical applications are:

- Exhaust ventilation shafts for drying processes
- Chimneys

⁹ A uniform flow field prevails in the largest part of the space cross-section.

- Quasi-parabolic flow profile

The system length is large compared to the cross-section surface and the flow velocity is so high that the ratios correspond to that of the circular pipe. This means that the same requirements apply here to the installation conditions.

Since the situation is similar to that in a pipe¹⁰, the volume flow in a square chamber can be calculated by equating the hydraulic diameter of both cross-section forms. The result for a rectangle "R" according to Figure 3-5 is a hydraulic "pipe diameter" D_H :

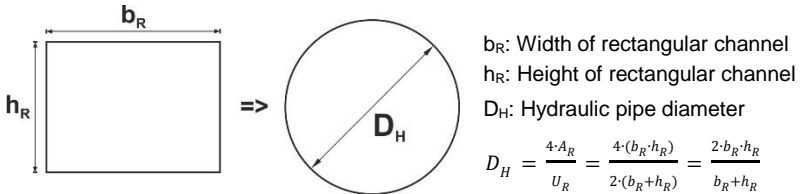

Figure 3-5

According to this, the volume flow in a shaft is calculated as:

$$A_H = \frac{\pi}{4} \cdot D_H^2 = \frac{\pi}{4} \cdot \left(\frac{2 \cdot b_R \cdot h_R}{b_R + h_R} \right)^2 = \pi \cdot \left(\frac{b_R \cdot h_R}{b_R + h_R} \right)^2$$

$$\bar{w}_N = PF \cdot w_N$$

$$\dot{V}_N = \bar{w}_N \cdot A_H = PF \cdot \pi \cdot \left(\frac{b_R \cdot h_R}{b_R + h_R} \right)^2 \cdot w_N$$

b_R / h_R	Width/height of the square chamber [m]
D_H	Hydraulic inner diameter of the chamber [m]
A_H	Cross-section area of the equivalent pipe [m ²]
w_N	Maximum flow velocity in the middle of the pipe [m/s]
\bar{w}_N	Average flow velocity in the pipe [m/s]
PF	Pipe profile factor
\dot{V}_N	Standard volume flow [m ³ /s]

Typical applications are:

- Ventilation shaft
- Exhaust air duct

¹⁰ The profile factors are equal for both cross-section forms.

Mounting with compression fitting

The compression fitting is mounted using a G $\frac{1}{2}$ or R $\frac{1}{2}$ external thread. Typically, a bushing is welded as a fitting onto a bore in the medium-guiding system wall. In most applications, these are pipes which are taken as an example for the description of the mounting procedure below (see Figure 3-6).

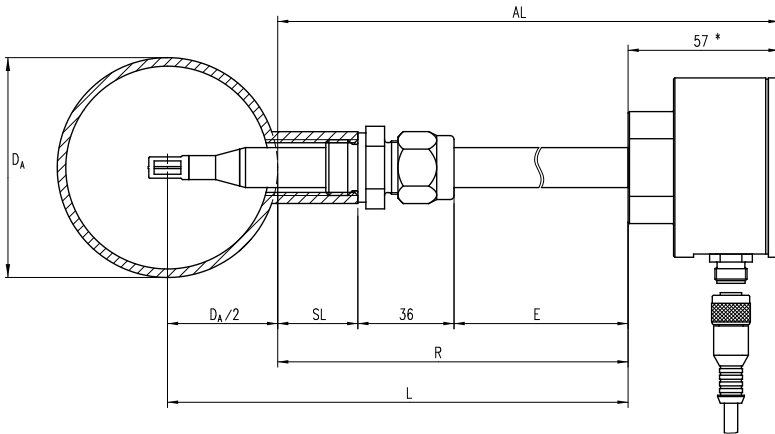

Figure 3-6

<i>L</i>	Probe length [mm]	<i>D_A</i>	Outer diameter of pipe [mm]
<i>SL</i>	Length of the weld-in sleeve [mm]	<i>E</i>	Sensor tube setting length [mm]
<i>AL</i>	Projecting length [mm]	<i>R</i>	Reference length [mm]

Installation process:



Depressurize the system for measurements with overpressure media and mount the pressure protection kit.

- Drill a mounting bore in a pipe wall.
- Weld the pipe union with an internal thread G $\frac{1}{2}$ or R $\frac{1}{2}$ in the center above the mounting opening on the pipe.
Recommended length of the pipe union: 15 ... 40 mm
- Plug the holding bracket of the pressure protection chain into the thread of the compression fitting.
- Screw the threaded part of the compression fitting tightly into the pipe union (hexagon AF27).
- Observe the correct seat and alignment of the chain bracket.
- Check if there is an O-ring seal available and if it is fitted tightly.
- Loosen the spigot nut of the compression fitting so that the sensor probe can be inserted without jamming.

- Remove the protective cap from the sensor head; carefully insert the sensor into the guide of the compression fitting so that the center of the chamber head is placed at the measuring position in the middle of the pipe.
- Adjust the sensor manually at the sensor enclosure by turning it counterclockwise by approx. 80° (observe the flow arrow on the housing cover). Make sure that the immersion depth is maintained.
- Tighten the spigot nut slightly by means of a key wrench (AF24) to fasten the sensor.
- Use a fork wrench (AF27) to lock the hexagon bolt at the screw pipe connection. Use another key wrench (AF24) to tighten the spigot nut of the compression fitting until the arrow on the sensor housing complies with the direction of the pipe flow.
- Check the set angular position carefully, for example by placing a bubble level on the aligning surface of the sensor enclosure.



The angular deviation should not be more than $\pm 3^\circ$ with respect to the ideal measuring direction. Otherwise, the measurement accuracy may be affected.

- In case of wrong adjustment, the compression fitting has to be loosened and the alignment procedure must be repeated.
- Shorten the safety chain by removing the superfluous chain links so that the chain is slightly tensioned after being locked at the housing. Finally, secure the chain with a padlock.

General note:



Do not use the alignment surface of the housing for mechanical adjustment, e.g. for locking.

There is risk of damage to the sensor.

Mounting of remote version

The sensor probe of the remote version is mounted with a compression fitting in the same way as the compact sensor.

A wall mounting bracket is provided for fastening the sensor housing.

Accessories

The accessories required for mounting and operation of the **SCHMIDT® Flow Sensor SS 20.600** are listed in Table 3 below.

Type / Art. no.	Drawing	Assembly
Connecting cable Standard with fixed length: 5 m 524921		<ul style="list-style-type: none"> - Threaded ring, knurl - Plug injection-moulded - Material: Brass, nickel-plated PUR, PVC
Connecting cable Standard with optional length: x m 524942		<ul style="list-style-type: none"> - Threaded ring, knurl - Material: Brass, nickel-plated Polyamide, PUR, PP Halogen-free¹¹
Coupler socket With thread locking 524929		<ul style="list-style-type: none"> - Threaded ring, knurl - Material: Brass, nickel-plated Polyamide, PUR, PP - Connection of wires: Screwed (0.25 mm²)
Clamp ¹² a.) 524916 b.) 524882		<ul style="list-style-type: none"> - Internal thread G½, R½ - Material: a.) Steel, black b.) Stainless steel 1.4571

Table 3 Accessories

Information about further accessories for mounting and display is available on the **SCHMIDT®** homepage:

www.schmidt-sensors.com or www.schmidttechnology.de

¹¹ According to IEC 60754

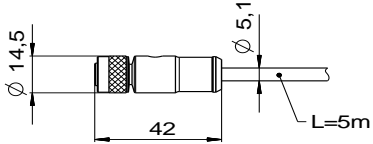
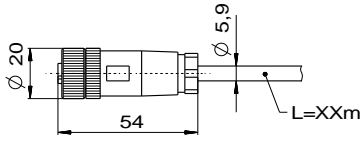
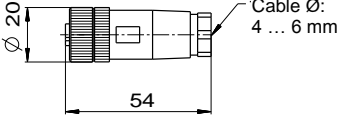
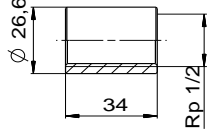
¹² According to EN 10241; must be welded.

4 Electrical connection



Make sure that no operating voltage is active during electrical installation and that the operating voltage cannot be switched on inadvertently.

The sensor is equipped with a plug-in connector which is firmly integrated in the housing (pin assignment see Table 4). The connector has the following data:

Number of connection pins:	8 (plus shield connection at the metallic housing)
Type:	Male
Fixation of connecting cable:	M12 thread (spigot nut at the cable)
Type of protection:	IP67 (with screwed cable)
Model:	Binder, series 763
Pin numbering:	

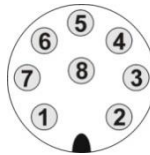

View on plug-in connector of sensor

Figure 4-1

Pin	Name	Function	Wire color
1	Pulse 1	Output signal: Flow / volume (digital: PNP)	White
2	U_B	Operating voltage: $24 V_{DC} \pm 20 \%$	Brown
3	Analog T_M	Output signal: Temperature of medium (Auto-U/I)	Green
4	Analog w_N	Output signal: Flow (Auto-U/I)	Yellow
5	AGND	Reference potential for analog outputs	Gray
6	Pulse 2	Output signal: Flow / volume (relay ¹³)	Pink
7	GND	Operating voltage: Ground	Blue
8	Pulse 2	Output signal: Flow / volume (relay ¹³)	Red
	Shield	Electromechanical shielding	Meshwork

Table 4

The specified wire colors are valid when one of the **SCHMIDT**[®] connecting cables is used (see subchapter *Accessories*, Table 3).

The analog signals have an own AGND reference potential.

The metal sensor housing is indirectly coupled to GND (with a varistor¹⁴, parallel to 100 nF) and should be connected to a protective potential, e.g. PE (depending on the shielding concept).



The appropriate protection class III (SELV) respective PELV (according EN 50178) has to be considered.

¹³ Galvanically decoupled

¹⁴ Voltage-dependant resistor (VDR); breakthrough voltage 27 V @ 1 mA

Operating voltage

The flow sensor **SS 20.600** is protected against reverse polarity of the operating voltage. For its intended operation, it requires a DC voltage of $24 V_{DC}$ with a tolerance of $\pm 20\%$.

Deviating values can lead to measurement errors or even defects and, therefore, should be avoided.



Operate the sensor only within the defined voltage range ($24 V_{DC} \pm 20\%$).

Undervoltage may result in malfunction; overvoltage may lead to irreversible damage.

The specifications for the operating voltage apply to the connection of the sensor. Voltage drops generated due to line resistances must be taken into account by the customer.

The typical operating current of the sensor (at nominal operating voltage, analog signal currents included, but without any of the impulse outputs) is approx. 80 mA, at maximum¹⁵ it requires 200 mA.

Wiring of analog outputs

Both analog outputs for flow and temperature are designed as high-side driver with “Auto-U/I” feature and are short-circuit protected against both rails of the operating voltage.

- Use of only one analog output

It is recommended to connect the same resistance value to both analog outputs, even if only one of them is used. For example, if only the “flow” output is operated in current mode with a resistance value of a few ohms, it is recommended to connect the other analog output (“medium temperature”) with the same resistance value or directly to AGND.

- Nominal operation

The load resistance R_L must be connected between the corresponding signal output and the electronic reference potential of the sensor (see Figure 4-2). Normally, AGND must be selected as measuring reference potential for the signal output. The supply line GND can also be used as reference potential, however, the ground offset can cause significant measurement errors in “Voltage” operating mode.



Typically, AGND has to be selected as measuring reference potential for the signal output.

¹⁵ Supply voltage minimal, both signal outputs with 22 mA, maximum signal current of impulse output, without signal current of output “Pulse “ (relay).

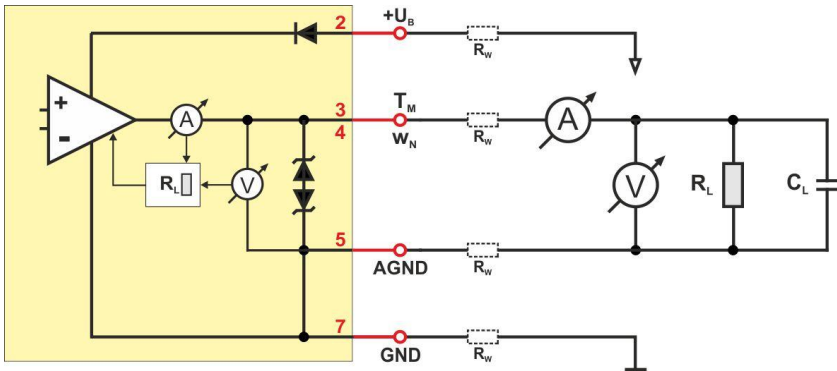

Figure 4-2

Depending on the value of load resistance R_L , the electronics switches between operation as voltage interface (mode: “U”) and current interface (mode: “I”) automatically, hence the designation “Auto-U/I”. The switching threshold is in range between 500 ... 550 Ω (for details refer to chapter 5 *Signaling*).

However, in voltage mode a low resistance value may cause significant voltage losses via the wire resistances R_W of the connection cable which can lead to measuring errors (“mass offset”).



For voltage mode, a measuring resistance of at least 10 k Ω is recommended.

The maximum load capacitance C_L is 10 nF.

- Short circuit mode

In case of a short circuit against the positive rail of the supply voltage (+ U_B), the signal output is switched off.

In case of a short circuit against the negative rail (GND) of the operating voltage, the output switches to current mode (R_L is calculated to 0 Ω) and provides the required signal current.

If the signal output is connected to + U_B via a resistance, the value R_L is calculated incorrectly and false signal values are caused.

Wiring of impulse output 1 (PNP)

The impulse output is current-limited, short-circuit protected and has the following technical characteristics:

Design:	Highside driver, open collector (PNP)
Minimum high level $U_{S,H,min}$:	$U_B - 3\text{ V}$ (with maximum switching current)
Maximum low level $U_{S,L,max}$:	0 V
Short circuit current limitation:	Approx. 100 mA
Maximum leakage current $I_{Off,max}$:	10 μA
Minimum load resistance $R_{L,min}$:	Depending on supply voltage U_B (see below)
Maximum load capacitance C_L :	10 nF
Maximum cable length:	100 m
Wiring:	

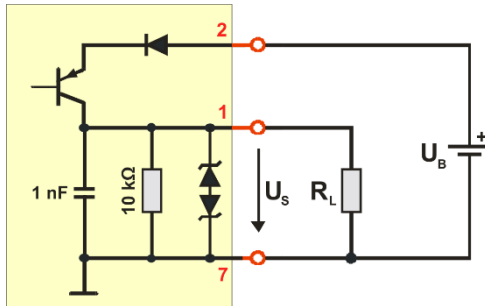

Figure 4-3

The impulse output can be used as follows:

- Direct driving of low-impedance loads (e.g. optocoupler, relays, etc.) with a maximum current consumption of approx. $I_{L,max} = 100\text{ mA}$.

This allows calculating the minimum permitted (static) load resistance $R_{L,min}$ depending on the operating voltage U_B ¹⁶:

$$R_{L,min} = \frac{U_B - 3\text{ V}}{I_{L,max}} = \frac{U_B - 3\text{ V}}{0.1\text{ A}}$$

Example:

In case of the maximum operating voltage of $U_{B,max} = 28.8\text{ V}$ the minimal load is $R_{L,min} = 258\ \Omega$.

Here the excessive heating power of the load has to be considered.

The pulse output is protected by means of different mechanisms:

- Current limiting:
The current is limited to approx. 100 mA (analog).
If the resistance values are too low, the length of the interconnection phases is limited to 100 μs .
The maximum load capacitance C_L is 10 nF. A higher capacitance reduces the limit of the current limiter.

¹⁶ Overcurrent peaks are absorbed by the short circuit limiter.



In case of a high capacitive load C_L , the inrush current impulse may trigger the quick-reacting short-circuit protection (permanently) although the static current requirement is below the maximum current $I_{S,max}$. An additional resistor connected in series to C_L can eliminate the problem.

- Protection against overvoltage.

The pulse output is protected against short-term overvoltage peaks (e.g. due to ESD or surge) of both polarities by means of a TVS diode¹⁷. Long-term overvoltage destroys the electronics.



Overvoltage can destroy the impulse output.

Wiring of impulse output 2 (relay)

The output is realized by a semiconductor relay with the following technical characteristics:

Technology:	SSR (PhotoMOS relay)
Maximum leakage current $I_{Off,max}$:	2 μ A
Maximum resistance R_{ON} :	16 Ω (typ. 8 Ω)
Maximum switching current I_S :	50 mA
Maximum switching voltage U_S :	30 V _{DC} / 21 V _{AC,eff}
Wiring:	

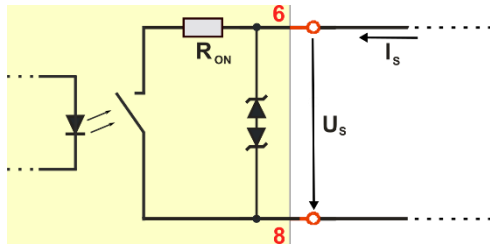

Figure 4-4

The relay output is protected against short-term overvoltage peaks (e.g. due to ESD or surge) of both polarities by means of a TVS diode. Long-term overvoltage destroys the electronics.



Exceeding the specified electrical operating values will lead to irreversible damage.

The output has no protective measures against incorrect wiring.

¹⁷ Transient Voltage Suppressor Diode, breakdown voltage 30 V, pulse 4 kW (8/20 μ s)

5 Signaling

LEDs

The **SCHMIDT® Flow Sensor SS 20.600** has four Duo-LEDs¹⁸ (see Figure 5-1) which indicate either flow velocity in fault-free operation in a quantitative way (bar graph mode) or signals the cause in case of problems (see Table 5).

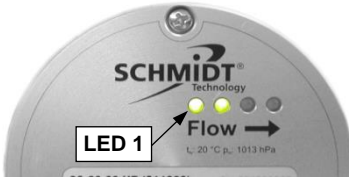

Figure 5-1

No.	State	LED 1	LED 2	LED 3	LED 4
1	Ready for operation & flow < 5 %	● (orange)	○	○	○
2	Flow > 5 %	● (green)	○	○	○
3	Flow > 20 %	● (green)	● (green)	○	○
4	Flow > 50 %	● (green)	● (green)	● (green)	○
5	Flow > 80 %	● (green)	● (green)	● (green)	● (green)
6	Flow > 100 % = overflow	● (green)	● (green)	● (green)	● (orange)
7	Sensor element defective	● (red)	● (red)	● (red)	● (red)
8	Operating voltage too low	● (red)	● (red)	○	○
9	Operating voltage too high	○	○	● (red)	● (red)
10	Electronic temperature too low	○	● (red)	● (red)	○
11	Electronic temperature too high	● (red)	○	○	● (red)
12	Medium temperature too low	● (orange)	● (red)	● (red)	● (orange)
13	Medium temperature too high	● (red)	● (orange)	● (orange)	● (red)

Table 5

- LED off
- LED on: green
- LED on: orange
- LED flashes¹⁹: red

¹⁸ Component with two integrated LEDs (red and green) that can be controlled individually and also indicate a mixed color (orange).

¹⁹ Approx. 1 Hz

Analog outputs

- Switching characteristic Auto-U/I

Interval of load resistance R_L	Signaling mode	Signaling range
≤ 500 (550) Ω	Current (I)	4 ... 20 mA
> 500 (550) Ω	Voltage (U)	0 ... 10 V

Table 6

A switching hysteresis of approx. 50 Ω ensures a stable transition behavior (see Figure 5-2).

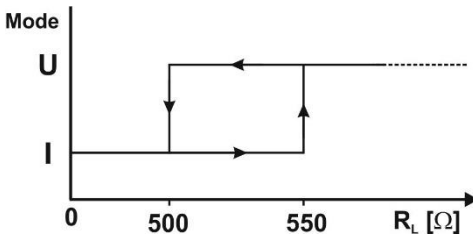

Figure 5-2

Depending on the provided output signal characteristic the accuracy of the switching point detection can be reduced. Therefore, it is recommended to select the load resistance such that a safe detection can be maintained ($\leq 300 \Omega$ for current mode and $\geq 10 \text{ k}\Omega$ for voltage mode).

To detect possible alternating load in an actual zero signal, the electronics generates test pulses that correspond to an effective value of approx. 1 mV. However, the latest measuring devices may trigger in response to such a pulse in DC voltage measuring mode and display short-term measuring values of up to 20 mV. In this case, it is recommended to install an RC filter at the measuring input with a time constant of 20 ... 100 ms.

- Error signaling

In current mode, the interface outputs 2 mA²⁰.

In voltage mode, the output switches to 0 V.

²⁰ In accordance with Namur specification.

- Representation of measuring range

The measuring range of the corresponding measuring value is mapped in a linear way to the mode-specific signaling range of the associated analog output.

For flow velocity measurement, it ranges from zero up to the selectable end of the measuring range $w_{N,max}$ (see Table 7).

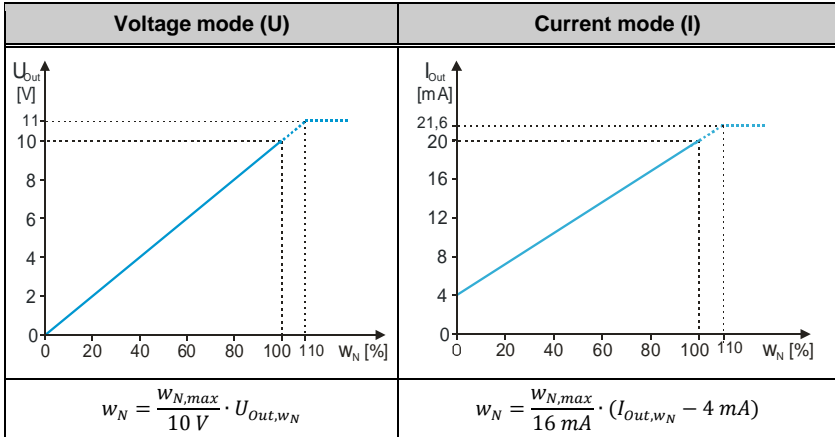

Table 7 Representation specification for flow velocity measurement

The measuring range of the medium temperature starts at the selected measuring range T_{Min} and ends at 120 °C (see Table 8).

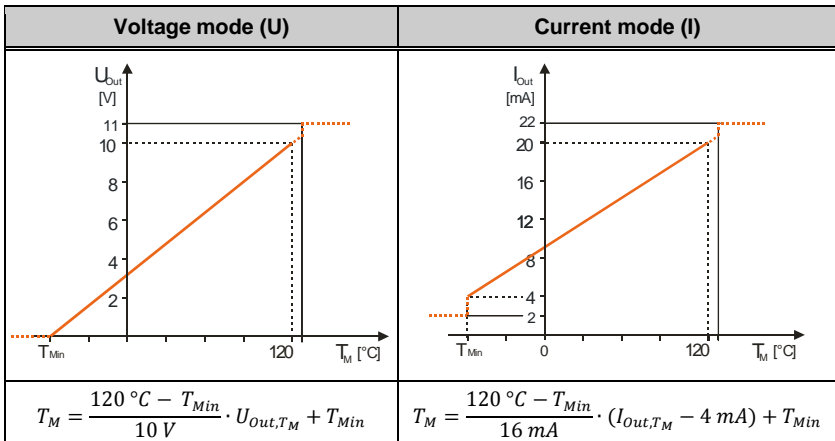

Table 8 Representation specification for measurement of medium temperature

- Exceeding measuring range of flow velocity w_N
 Measuring values larger than $w_{N,max}$ are output linearly up to 110 % of the signaling range (this corresponds to 11 V resp. 21.6 mA, see graphics in Table 7). At higher values of w_N , the output signal remains constant.
 In that case an error signaling does not take place because damage of the sensor is unlikely.
- Medium temperature T_M outside specification range
 Operation beyond the specified limits can lead to damages of the sensor and, therefore, is seen as a critical error. This leads to the following reaction depending on the temperature limit (also refer to the graphics in Table 8):
 - Medium temperature below lower temperature limit:
 The analog output for T_M switches to error (0 V or 2 mA)²¹.
 The measuring function for the flow velocity is switched off its analog output also signals an error (0 V resp. 2 mA).
 - Medium temperature above 120 °C
 T_M is output in a linear way up to at least 130 °C, e.g. to enable overshooting of heating control. The flow velocity is measured and displayed further on.
 Above this critical limit, flow measurement is switched off and the analog output w_N switches to error signaling (0 V or 2 mA). The signal output T_M switches directly to the maximum possible values of 11 V resp. 22 mA, in opposition to normal error signaling.
 This prevents that a heating control which is using the medium temperature measuring function of the sensor gets into a critical self-excitation in case of overtemperature. A normal error signaling (0 V or also 2 mA) could be identified by the control as very low temperature of the medium which would lead to further heating.

²¹ The switching hysteresis for the threshold is approx. 5 K.

Pulse outputs

The two pulse outputs provide the same measured variable, which depends on the sensor configuration:

- In standard configuration the sensor maps the flow velocity w_N proportional to a frequency range $[0 \dots f_{max}]$, with selectable maximum frequency f_{max} (see Figure 5-3).

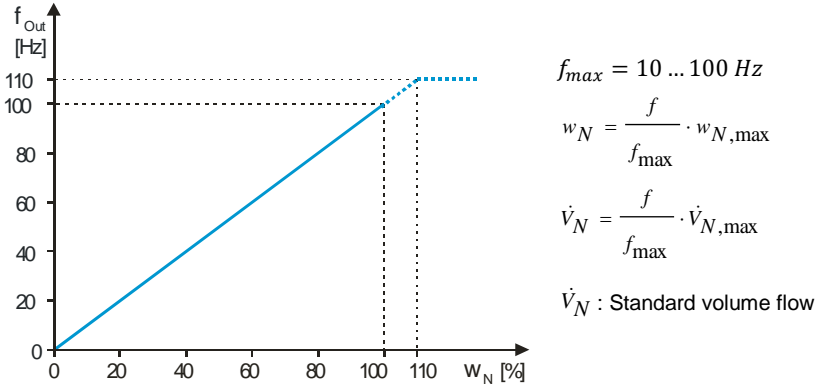

Figure 5-3 Example for $f_{max} = 100 \text{ Hz}$

The volume flow \dot{V}_N and the pulse valence $V_{N,Imp}$ (= volume per pulse) can be determined on base of the actual output frequency, the measuring range $w_{N,max}$ of the sensor and the inner pipe diameter D :

$$\dot{V}_N = w_N \cdot PF \cdot A_D = w_N \cdot PF \cdot \frac{\pi}{4} \cdot D^2; \quad V_{N,Imp} = \frac{\dot{V}_{N,max}}{f_{max}}$$

- When configured as a consumption meter, pulses with a predefined pulse valency (e.g. $1 \text{ m}^3/\text{pulse}$) are transmitted. To do this, the inner pipe diameter D must be specified when ordering ($D_{min} = 25 \text{ mm}$).

Exceeding the measuring range of the flow w_N is also output linearly up to 110 % of the measuring range. The output of higher flow values is limited to 110 % of the measuring range.

If an error occurs, 0 Hz or no pulses will be output. The current initial state remains unchanged.

Note:

The relay can be used as “S0-Interface” according to EN 62053-31²².

²² Former standard: DIN 43 864

6 Commissioning

Prior to switching on the **SCHMIDT® Flow Sensor SS 20.600**, the following checks have to be carried out:

- Mechanical installation:
 - Correct immersion depth and alignment of the sensor probe according to the flow direction
 - Tightening of the fastening screw or spigot nut
 - Installation of the pressure safety devices



For measurements in media with overpressure, check if the fastening screw is tightened properly and pressure safety devices are installed.

- Connecting cable:
 - Correct connection in the field (switch cabinet or similar)
 - Tightness of the sensor connector and connecting cable (flat seal must be inserted correctly into the female cable connector)
 - Tight fit of spigot nut on the cable connector at the sensor housing

After switching on the operating voltage, the sensor signals its initialization by switching all four LEDs sequentially to red, orange and green.

If the sensor detects a problem during initialization, it signals the problem according to Table 5. An extensive overview of possible errors, their causes as well as troubleshooting measures are listed in Table 9.

If the sensor is operating as intended after the initialisation, it switches into regular measuring mode. For a short period the flow velocity indication (both LEDs and signal outputs) goes to maximum and settles to the correct measuring value after about 10 seconds, provided the sensor probe was already at medium temperature. Otherwise, the process will last longer until the sensor has reached the medium temperature.

7 Information concerning operation

Environmental condition Temperature

The **SCHMIDT® Flow Sensor SS 20.600** monitors the temperature of both medium and electronics. As soon as the specified operating range of the electronics (-20 ... +70 °C) is exceeded, the sensor switches off both measuring functions associated with the medium and signals the error by means of the LED bar according to Table 5. As soon as proper operational conditions are restored, the sensor resumes measuring mode.



Even when exceeding or underrunning the operating temperatures for a short time, the sensor may be damaged irreversibly.

Environmental conditions Medium

The **SCHMIDT® Flow Sensor SS 20.600** is also suitable for relatively impure gases provided that no harmful, chemical aggressive constituents²³ are included. Dust or non-abrasive particles can be tolerated as long as they do not form any deposits on the sensor chip.

Deposits or other soiling must be detected during regular inspections and removed during cleaning because they can lead to distortion of the measurement result (see chapter 8 *Service information*).



Dirt or other deposits on the sensor head cause false measurement results.

Therefore, the sensor must be checked for contamination at regular intervals and cleaned if necessary.

Condensing liquid components in the measuring medium or even immersion of the sensor probe into liquids must be avoided at all costs.



Always avoid liquids on the sensor during operation.

It leads to serious measurement distortions and can damage the sensor in the long term.



When using the sensor outdoors, it must be protected against direct exposure to the weather.

²³ Strong mineral acids e.g. can be critical; in general the suitability has to be checked.

8 Service information

Maintenance

Heavy soiling of the sensor head may lead to distortion of the measured value. Therefore, the sensor head must be checked for contamination at regular intervals. If contaminations are visible, the sensor can be cleaned as described below.

Cleaning of sensor head

If the sensor head is soiled or dusty, it must be cleaned carefully by means of compressed air.



The sensor head is a sensitive measuring system. During manual cleaning proceed with great care.

In case of persistent deposits, the sensor chip as well as the interior of the chamber head can be cleaned carefully by using residue-free drying alcohol (e.g. isopropyl alcohol) or soapy water with special cotton swabs.



Figure 8-1 Suitable cotton swabs with small cleaning pads

Suitable for this purpose are cotton swabs which have small, flattened and soft cotton pads (example see Figure 8-1). The flat side of that pad should fit just between chamber wall and sensor chip to allow the exertion of a controlled, minimal pressure on the chip. Conventional cotton swabs (e.g. for ear cleaning) are typically too big and therefore can break the chip.



Under no circumstances do attempt to pressurize the chip with greater force (e.g. by swabs with thick head or lever movements with its stick). Mechanical overloading of the sensor element can lead to irreversible damage.









The stick may only be moved with great care back and forth parallel to the chip surface to rub off the dirt. If necessary, use several cotton swabs. Before recommissioning, the sensor head must be completely dry. The drying process can be accelerated by gently blowing. If this procedure does not help, the sensor must be sent to **SCHMIDT Technology** for cleaning or repair.

Eliminating malfunctions

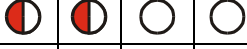
The following Table 9 lists possible errors (error images). A description of the way to detect errors is given. Furthermore, possible causes and measures to be taken to eliminate errors are listed.



Causes of any error signaling have to be eliminated immediately. Significant exceeding or falling below the permitted operating parameters can result in permanent damage to the sensor.

Error image	Possible causes	Troubleshooting
 No LED is lit All signal outputs at zero	Problems with supply voltage U_B : > No U_B present > U_B has wrong polarity > $U_B < 15\text{ V}$ Sensor defective	> Plug-in connector of cable screwed on correctly? > Supply voltage connected to control? > Supply voltage at sensor plug available; cable break? > Sufficient power supply? > Send sensor in for repair
Start sequence is repeated continuously (all LEDs red - yellow - green)	U_B unstable: > Power supply unable to supply switch-on current > Supply overloaded by other devices > Wire resistance too high	> Is supply voltage at sensor stable? > Is supply power sufficient? > Voltage losses over cable negligible?
	Sensor element defective	Return sensor for repair
	Supply voltage too low	Increase supply voltage
	Supply voltage too high	Reduce supply voltage
	Electr. temperature too low	Increase operating temperature of environment
	Electr. temperature too high	Lower operating temperature of environment
	Medium temperature too low	Increase medium temperature
	Medium temperature too high	Lower medium temperature

Error image	Possible causes	Troubleshooting
Low signal w_N is too large / small	Measuring range too small / large I-mode instead of U-mode or vice versa Medium to be measured does not correspond to adjustment medium Sensor element soiled	Check sensor configuration Check type or load resistance Is foreign gas correction considered? Clean sensor head
Flow signal w_N is fluctuating	U_B unstable Mounting conditions: ➤ Sensor head is not in the optimum position ➤ Inlet or outlet is too short Strong fluctuations of pressure or temperature	Check voltage supply Check mounting conditions Check operating parameters
Analog signal voltage permanently at maximum	Load resistance of signal output connected to $+U_B$	Connect load resistance to AGND
Analog signal voltage permanently at zero	Error signaling Short circuit against (A)GND	Eliminate errors Eliminate short circuit

Table 9

Transport / Shipment of the sensor

Before transport or shipment of the sensor, the delivered protective cap must be placed onto the sensor head.

Avoid contaminations or mechanical stress.

Calibration

If the customer has made no other provisions, we recommend repeating the calibration at a 12-month interval.

For this, the sensor must be sent in to the manufacturer.

Spare parts or repair

No spare parts are available, since a repair is only possible at the manufacturer's facilities. In case of defects, the sensor must be sent in to the supplier for repair.

- **A completed declaration of decontamination must be attached.**

The appropriate form "Declaration of decontamination" is enclosed with the sensor and can also be downloaded at

www.schmidt-sensors.com

tab "Service & Support for Sensors", heading "Product downloads".

Alternatively it can be downloaded from

www.schmidttechnology.de

tab "Service & Support für Sensorik", heading "Produkt-Downloads".

If the sensor is used in systems important for operation, we recommend you to keep a replacement sensor in stock.

Test certificates and material certificates

Every new sensor is accompanied by a certificate of compliance according to EN 10204-2.1. Material certificates are not available.

Upon request, we shall prepare, at a charge, a factory calibration certificate, traceable to national standards.

9 Dimensions

Compact sensor

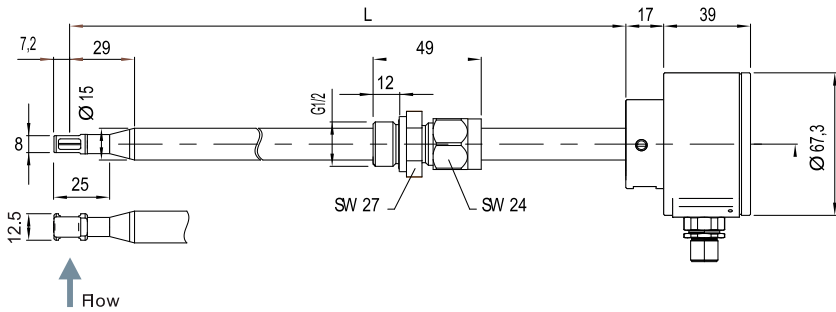

Figure 9-1

Remote sensor including wall mounting bracket

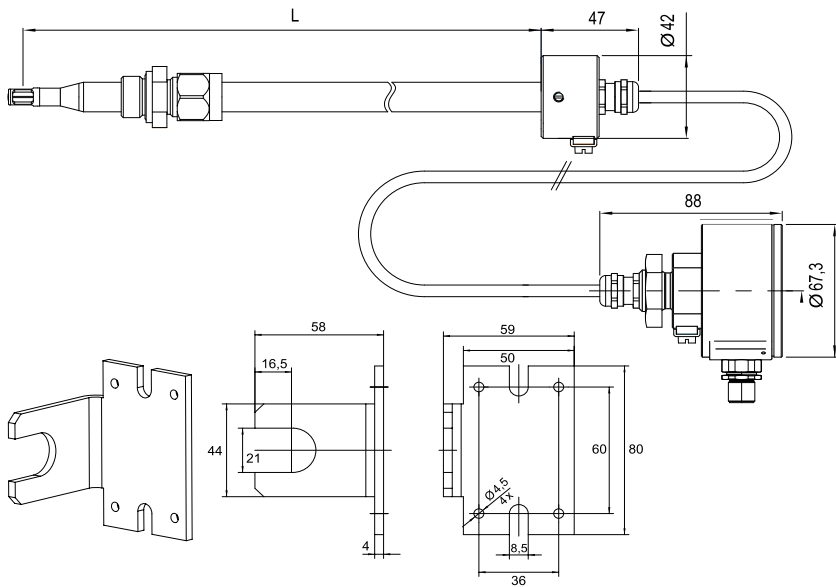

Figure 9-2

10 Technical data

Measurement-specific data	
Measuring values	Standard velocity w_N based on standard conditions of 20 °C and 1,013.25 hPa Temperature of medium T_M
Medium to be measured	Standard: Air or nitrogen Optional: Natural gas, biogas, CO ₂ and special gases or gas mixtures
Measuring range w_N	Standard: 0 ... 10 / 20 / 60 / 90 / 140 / 220 m/s Special: 10 ... 220 m/s (steps: 0.1 m/s)
Lower detection limit w_N	0.2 m/s
Measuring range T_M	Standard / O ₂ version: -20 ... +120 °C ATEX version: -40 ... +120 °C
Measuring accuracy	
Standard w_N	± 3 % o. m. v. + (0.4 % o. f. v.; min. 0.08 m/s) ²⁴
High precision w_N	± 1 % o. m. v. + (0.4 % o. f. v.; min. 0.08 m/s) ²⁴ (only for air, nitrogen, oxygen)
Response time (t_{90}) w_N	1 s (jump of w_N from 0 to 5 m/s in air)
Temperature gradient w_N	< 8 K/min (at $w_N = 5$ m/s)
Recovery time constant	< 10 s (temperature jump $\Delta\theta = 40$ K at $w_N = 5$ m/s)
Measuring accuracy ²⁵ T_M	± 1 K (10 ... 30 °C) ± 2 K remaining measuring range
Operating temperature	
Sensor probe	Standard: -20 ... +120 °C O ₂ version: -20 ... +60 °C ATEX version: -40 ... +120 °C
Electronics	-20 ... +70 °C
Storage temperature	-20 ... +85 °C
Material	
Enclosure	Anodized aluminum
Sensor tube	Stainless steel 1.4571
Compression fitting	Stainless steel 1.4571, NBR (or FKM)
Sensor head	Platinum element (glass passivated) Standard: PPO / PA Option: Stainless steel 1.4571 with Parylene coating
Sensor cable (remote sensor)	Sheathing TPE, halogen-free

²⁴ „o. m. v.“: of measured value; „o. f. v.“: of final value; under reference conditions

²⁵ $w_N > 2$ m/s

General data	
Humidity range	Measuring mode: Non-condensing ($\leq 95\%$ RH)
Operating pressure (max.)	Standard version: 16 bar Oxygen version: 20 bar Optional version: 40 bar
Display	4 x Duo-LEDs (green / red / orange)
Supply voltage	24 V _{DC} \pm 20 %
Current consumption	Typ. 80 mA (without pulse outputs); max. 200 mA ²⁶
Analog outputs - Type: Auto U / I Switching Auto-U/I - Voltage output - Current output - Switching hysteresis Maximum load capacitance	Flow velocity, temperature of medium Automatic switching of signal mode based on load R _L 0 ... 10 V for R _L \geq 550 Ω 4 ... 20 mA for R _L \leq 500 Ω 50 Ω 10 nF
Pulse outputs - Signaling: - Pulse output 1: - Pulse output 2:	f ~ w _N : 0 m/s ... w _{N,max} \rightarrow 0 Hz ... f _{max} Standard: f _{max} = 100 Hz Option : f _{max} = 10 ... 99 Hz Option: 1 pulse / 1 m ³ 1 pulse / 0.1 m ³ 1 pulse / 0.01 m ³ (max. 100 Hz) High-side driver connected to supply voltage (PNP; without galvanic separation) High level: > supply voltage - 3 V Short circuit current limitation: 100 mA Leakage current: I _{off} < 10 μ A Semiconductor relay (output galvanically separated) Max. 30 V _{DC} / 21 V _{AC,eff} / 50 mA
Connection	Plug-in connector M12 (A-coded), 8-pin, male, screwed
Maximum cable length	Voltage signal: 15 m, current signal / pulse: 100 m
Installation position	Arbitrary (for vertical downdraft flow: lower range limit is 2 m/s at 16 bar)
Mounting tolerance	$\pm 3^\circ$ relative to flow direction (unidirectional)
Minimum immersion depth	DN25
Type of protection	IP65 (housing), IP67 (sensor probe)
Protection class	III (SELV) or PELV (according EN 50178)
ATEX category	II 3G Ex ec ic IIC T4 Gc II 3D Ex ic tc IIIC T135°C Dc
Probe length L - Compact sensor - Remote sensor	Standard: 120 / 250 / 400 / 600 mm Special: 120 ... 1,000 mm (increment: 10 mm) Probe: 120 / 250 / 400 / 600 mm Cable: 10 m (increment: 1 m)
Weight	Approx. 500 g max. (without connecting cable)

²⁶ Without signal current of pulse output 2 (relay)

11 Declarations of conformity

SCHMIDT Technology GmbH herewith declares in its sole responsibility, that the product

SCHMIDT® Flow Sensor SS 20.600

Part-No. **524 600**

is in compliance with the appropriate



European guidelines and standards

and



UK statutory requirements and designated standards.

The corresponding declarations of conformity can be download from **SCHMIDT®** homepage:

www.schmidt-sensors.com

www.schmidttechnology.de



SCHMIDT Technology GmbH

Feldbergstraße 1
78112 St. Georgen
Germany

Phone +49 (0)7724 / 899-0

Fax +49 (0)7724 / 899-101

Email sensors@schmidttechnology.de

URL www.schmidt-sensors.com
www.schmitttechnology.de