

Simply a question of
better measurement

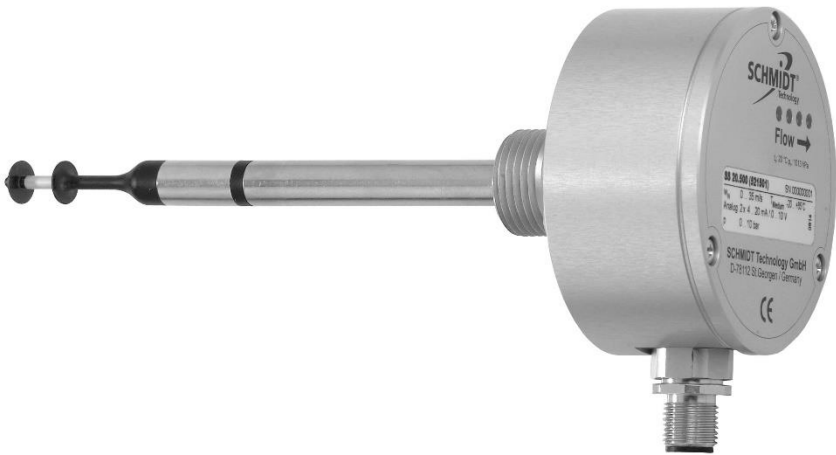

SCHMIDT® Flow Sensor SS 20.500 Instructions for Use

SCHMIDT® Flow Sensor SS 20.500

Table of Contents

1	Important information.....	3
2	Application range.....	4
3	Mounting instructions.....	5
4	Electrical connection.....	21
5	Signalling.....	24
6	Commissioning.....	28
7	Information concerning operation.....	29
8	Service information.....	31
9	Technical data.....	34
10	Declarations of conformity.....	35

Imprint:

Copyright 2021 **SCHMIDT Technology GmbH**

All rights reserved

Version 523375.02G

Subject to modifications

1 Important information

The instructions for use contain all required information for a fast commissioning and a safe operation of **SCHMIDT®** flow sensors.

- These instructions for use must be read completely and observed carefully, before putting the unit into operation.
- Working on a pressurized system as well as assembly, electrical installation, commissioning and operation of the sensor may only be carried out by trained specialists. Safety and accident prevention regulations must be observed.
- Any claims under the manufacturer's liability for damage resulting from non-observance or non-compliance with these instructions will become void.
- Tampering with the device in any way whatsoever - with the exception of the designated use and the operations described in these instructions for use - will forfeit any warranty and exclude any liability.
- The unit is designed exclusively for the use described below (refer to *chapter 2*). In particular, it is not designed for direct or indirect protection of personal and machinery.
- **SCHMIDT Technology** cannot give any warranty as to its suitability for certain purpose and cannot be held liable for accidental or sequential damage in connection with the delivery, performance or use of this unit.

Symbols used in this manual

All the symbols used in this manual are explained in the following section.



Danger warnings and safety instructions - please read them carefully!

Non-observance of these instructions may lead to personal injury or malfunction of the device.

General note

All dimensions are indicated in mm.

2 Application range

The **SCHMIDT® Flow Sensor SS 20.500** (article number 521501) is designed for stationary measurement of the flow velocity as well as the temperature of air and gas at working (over)pressure of up to 10 bar¹.

The sensor is based on the measuring principle of a thermal anemometer and measures the mass flow of the measuring medium as flow velocity, which is output in a linear way as standard velocity² w_N , based on standard conditions of 1,013.25 hPa and 20 °C. Thus, the resulting output signal is independent from the pressure and temperature of the measuring medium.

The sensor has the following special features in connection with its unique patented sensor tip design:

- Omnidirectional measurement
- High sensitivity (lower measuring threshold: 0.06 m/s)
- High turn down ratio (max. measuring range: 50 m/s)
- Free of undercuts
- Sterilisable using hydrogen peroxide³, alcohols etc.
- High soiling tolerance
- High chemical media resistance⁴

These features predetermine that the sensor is used, for example in:

- Clean rooms
- Flow channel or duct
- Free-space application



When using the sensor outdoors, it must be protected against direct exposure to the weather.

Mechanical versions

The sensor **SS 20.500** is available in a version as compact sensor (probe is fixed at housing) and as a remote sensor (the probe is connected with its sensor housing via a cable).



The remote version is limited to atmospheric applications.

¹ Only compact sensor; remote version is limited to atmospheric applications.

² Corresponds to the actual velocity under standard conditions.

³ Use of hydrogen peroxide only with uncoated version.

⁴ Especially with optional coatings.

3 Mounting instructions

General information on handling

The flow sensor **SS 20.500** is a precision instrument with high measuring sensitivity, which can be achieved only by means of fine structure of the measuring probe (see Figure 3-1). Therefore, avoid applying mechanical force to the probe tip.

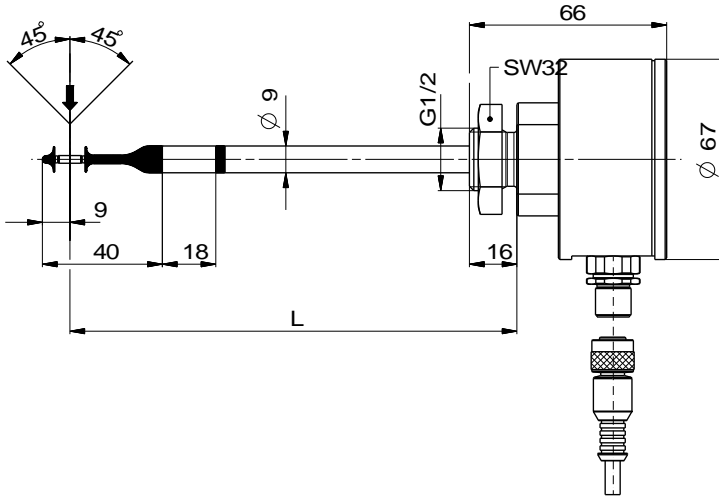

Figure 3-1

Especially when inserting or extracting the probe into/from through-channels (e.g. in a compression fitting) even slight tilting can lead to damage of the tip.

Therefore, **SCHMIDT Technology** delivers the sensor with a protective cap⁵ placed onto the probe tip, which should be removed only during final installation in longitudinal direction. Moreover, vice versa when dismantling the sensor the protective cap must be attached in place immediately. When handling the sensor generally proceed with great care.



The sensor probe can be damaged irreversibly due to mechanical loads.

Leave the protective cap during mounting as long as possible attached and handle the sensor with care.

⁵ Made of coloured polycarbonate

Systems with overpressure

The compact version of the **SS 20.500** is designed for a maximum working pressure⁶ of 10 bar. As long as the medium to be measured is operated with overpressure, make sure that:

- There is no overpressure in the system during mounting.



Mounting and dismounting of the sensor in pipes can be carried out only as long as the system is **in depressurized state**.

- Only suitable pressure-tight mounting accessories are used.
- Appropriate safety devices are installed to avoid unintended discarding of the sensor due to overpressure.



For measurements in media with overpressure, appropriate safety measures must be taken to prevent unintended discarding of the sensor.

The compression fittings available from **SCHMIDT Technology** for overpressure applications (see subchapter "*Accessories*") contain a pressure protection kit designed especially for this purpose. In case of other accessories or alternative mounting solutions the customer must ensure corresponding safety measures.



The components of the pressure protection kit (bolt, chain and bracket) have to be checked regularly for integrity.

Flow characteristics

Local turbulences of the medium can cause distortion of measurement results. Therefore, appropriate installation conditions must be guaranteed to ensure that the gas flow is supplied to the measuring probe in a laminar⁷ state, i.e. quiet and low in turbulence. The corresponding measures depend on the system properties (pipe, flow box, free-space application etc.), they are described in the following subchapters for different mounting variants.



Correct measurements require laminar flow with as low turbulence as possible.

⁶ Overpressure

⁷ The term "laminar" means here an airflow low in turbulence (not according to its physical definition saying that the Reynolds number is < 2300).

The probe element of the **SS 20.500** consists of two basic elements (see Figure 3-2):

- The heated measuring element in the probe tip (heater):
The dumbbell-shaped probe tip enables an omnidirectional flow measurement vertically to the longitudinal axis of the probe. Furthermore, the flow guiding disks allow deviation from the strictly vertical direction of detection of up to $\pm 45^\circ$ (see Figure 3-1) without significant impact on the measurement result⁸.

The center of the dumbbell-shaped element also referred to by specification of probe length (L) is the actual measuring point of the flow measurement and must be placed in the flow as advantageous as possible, for example in the center of the pipe (also see Figure 3-5).



Position the dumbbell-shaped segment always at the position most advantageous for the flow measurement.

- The measuring sleeve for measurement of the temperature of the medium (T-sleeve):

The sleeve must be positioned directly in the flow field (see Figure 3-2) to be able to detect changes of the medium temperature directly.

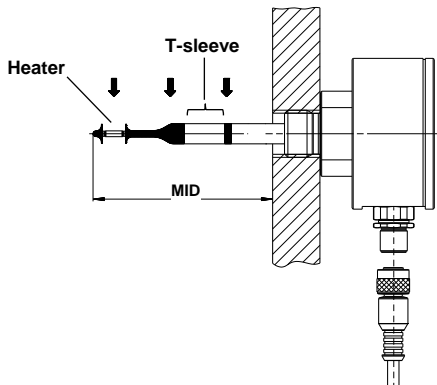

Figure 3-2

The minimum immersion depth (MID) of the probe required here is 58 mm. The sleeve must not contact the mounting fixture, the wall or similar because this will cause deviations of the flow and temperature measurement.



The temperature-measuring sleeve must be positioned directly in the main flow.

⁸ Deviation < 1 % of the measured value

Mounting in pipes with circular cross-section

The mounting in a flow guiding pipe is carried out by means of a compression fitting (for details refer to subchapter "*Mounting with compression fitting*").

The installation of the sensor must be performed at the point with laminar (low turbulence) flow profile to guarantee correct measurement results. The easiest method to achieve this is to provide a sufficiently long and straight measuring distance without disturbances (such as edges, seams, bends etc.) in front (inlet) and behind the sensor (outlet; see installation drawing Figure 3-3). It is also necessary to pay attention to the design of the outlet distance because disturbances also generate turbulences against flow direction.

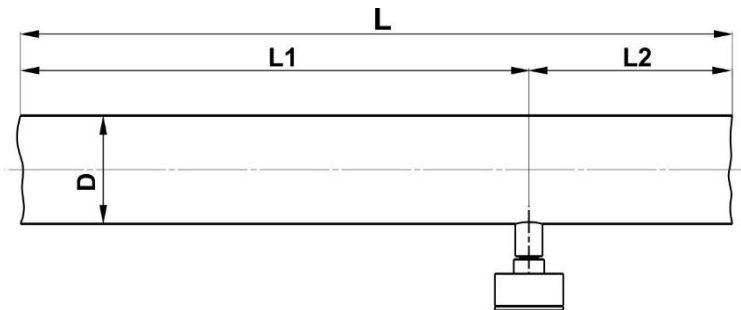

Figure 3-3

- L Length of whole measuring distance
- L1 Length of inlet distance
- L2 Length of outlet distance
- D Inner diameter of measuring section

The absolute length of the corresponding measuring distance is defined by the inner diameter of the pipe because the flow calming effect depends directly on the aspect ratio of the measuring distance to diameter. Therefore, the required calming distances are specified as a multiple of the pipe diameter D . Furthermore, the degree of turbulence generated by the respective interference object plays a major role. A slightly curved bend directs the air with relative low disturbance level compared to a valve generating massive turbulences with its abrupt change of the flow-guiding cross-section requiring a relatively long measuring distance for calming.

Table 1 shows the required calming distances (in relation to the pipe inner diameter D) for different disturbances.

Flow obstacle upstream of measuring section		Minimum length of distance	
		Inlet (L1)	Outlet (L2)
Light bend (< 90°)		10 x D	5 x D
Reduction, expansion, 90° bend or T-junction		15 x D	5 x D
Two 90° bends in one plane (2-dimensional)		20 x D	5 x D
Two 90° bends with 3-dimensional change in direction		35 x D	5 x D
Shut-off valve		45 x D	5 x D

Table 1

This table lists the *minimum values* required in each case. If it is not possible to observe the specified calming distances, increased deviations of the measurement results are to be expected or it is necessary to take additional measures, for example to use flow rectifiers⁹.

Under laminar conditions a quasi-parabolic speed profile is formed over the pipe cross-section, whereas the flow velocity at the pipe walls remains almost zero, in the middle of the pipe it reaches the optimum measuring point, its maximum w_N . This measurement value can be converted to an average speed $\overline{w_N}$ constant over the pipe cross-section by means of a correction factor, the so-called profile factor PF. The profile factor depends on the pipe diameter¹⁰ and is given in Table 2.

⁹ For example, honeycombs made of plastic or ceramics; profile factor may change.

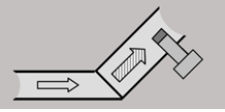
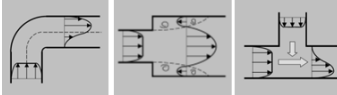
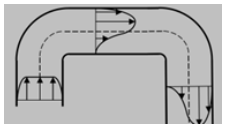
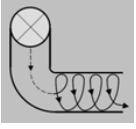
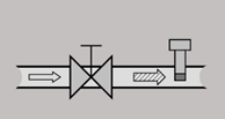
¹⁰ Here interior air friction as well as obstruction caused by sensor is considered.

Thus, it is possible to calculate the standard volumetric flow of the medium using the measured standard flow velocity in a pipe with known inner diameter:

$$A = \frac{\pi}{4} \cdot D^2$$

$$\bar{w}_N = PF \cdot w_N$$

$$\dot{V}_N = \bar{w}_N \cdot A$$

D Inner diameter of pipe [m]

A Cross-section area of pipe [m²]

w_N Standard flow velocity in pipe centre [m/s]

\bar{w}_N Average standard flow velocity in tube [m/s]

PF Profile factor (for pipes with circular cross-sections)

\dot{V}_N Standard volumetric flow [m³/s]

PF	Pipe Ø		Measuring range of volumetric flow [m ³ /h]				
	Inner [mm]	Outer [mm]	For sensor measuring range				
			1 m/s	2.5 m/s	10 m/s	20 m/s	35 m/s
0.710	70.3	76.1	10	25	99	198	347
0.710	76.1	82,5	12	29	116	233	407
0.720	82.5	88.9	14	35	139	277	485
0.740	100.8	108.0	21	53	213	425	744
0.750	107.1	114.3	24	61	243	486	851
0.760	125.0	133.0	34	84	336	672	1.175
0.775	131.7	139.7	38	95	380	760	1.330
0.795	150.0	159.0	51	126	506	1,012	1,770
0.810	159.3	168.3	58	145	581	1,162	2,034
0.820	182.5	193.7	77	193	772	1,544	2,703
0.840	206.5	219.1	101	253	1,013	2,026	3,545
0.840	260.4	273.0	161	403	1,610	3,221	5,637
0.845	309.7	323.9	229	573	2,292	4,583	8,020
0.845	339.6	355.6	276	689	2,755	5,511	9,644
0.850	388.8	406.4	363	908	3,633	7,266	12,715
0.850	437.0	457.0	459	1,147	4,590	9,179	16,064
0.850	486.0	508.0	568	1,419	5,677	11,353	19,868
0.850	534.0	559.0	685	1,713	6,853	13,706	23,986
0.850	585.0	610.0	822	2,056	8,225	16,450	28,787
0.850	631.6	660.0	959	2,397	9,587	19,175	33,555

Table 2

SCHMIDT Technology provides a "flow calculator" on its homepage (page: "Service & Support") for the calculation of flow velocity or volume flow in pipes or ducts for various sensor types:

www.schmidt-sensors.com

or

www.schmidttechnology.de

Mounting in ducts with rectangular cross-section

In most applications, this is a room or shaft with a rectangular cross-sectional area through which flow passes. Based on flow conditions there is a distinguishment between two cases:

- Quasi-uniform flow field

The lateral dimensions of the flow guiding system are approximately as large as its length in flow direction and flow velocity is relatively small so that a laminar trapezoidal¹¹ speed profile of the flow is formed. The width of the flow gradient zone at the wall is negligible relatively to chamber width so that a constant flow velocity can be assumed over the whole chamber cross-section. The sensor must be mounted here in such a way that its sensor tip is far enough from the wall and it measures in the area with constant flow field.

Typical applications are:

- Flow box
- Clean rooms

- Quasi-parabolic flow profile

The system length is large compared to the cross-section surface and flow velocity is so high that the ratios correspond to that of a circular pipe. This means that the same requirements apply here to installation conditions.

Since the situation is similar to that in a pipe¹², the volumetric flow in a square chamber can be calculated by equating the hydraulic diameter of both cross-sections. As a result, the rectangle according to Figure 3-4 equals to a pipe with the hydraulic diameter D_R :

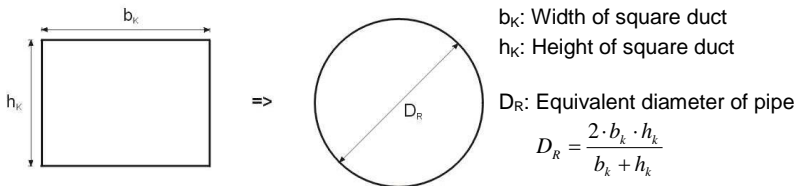

Figure 3-4

¹¹ A uniform flow field prevails in the largest part of the room cross-section.

¹² The profile factor of the equivalent pipe is equal to a "normal" pipe with diameter D_R .

According to this, the volumetric flow in a square duct is calculated as follows:

$$A_R = \frac{\pi}{4} \cdot D_R^2 = \frac{\pi}{4} \cdot \left(\frac{2 \cdot b_K \cdot h_K}{b_K + h_K} \right)^2 = \pi \cdot \left(\frac{b_K \cdot h_K}{b_K + h_K} \right)^2$$

$$\bar{w}_N = PF \cdot w_N$$

$$\dot{V}_N = \bar{w}_N \cdot A_R = PF \cdot \pi \cdot \left(\frac{b_K \cdot h_K}{b_K + h_K} \right)^2 \cdot w_N$$

b_K	Width of square duct [m]
h_K	Height of square duct [m]
D_R	Inner diameter of equivalent pipe [m]
A_R	Cross section area of equivalent pipe [m ²]
w_N	Max. standard flow velocity in duct centre [m/s]
\bar{w}_N	Average standard flow velocity in equivalent pipe [m/s]
PF	Profile factor of equivalent pipe
\dot{V}_N	Standard volumetric flow [m ³ /s]

Typical applications are:

- Ventilation shaft
- Exhaust air duct

Mounting in a straight wall

In general there are three options available for sensor installation on or (directly) in a wall:

- Screw thread of sensor housing:

The housing has an external thread G $\frac{1}{2}$ (16 mm long) for direct mounting on or in the medium separating wall. Its advantage is in the simplicity of installation without special accessories; however, the immersion depth is defined by the probe length in this case.

For detailed description of the mounting procedure refer to subchapter "*Direct mounting*".

- Mounting flange from **SCHMIDT**[®] accessories:

Designed as an easy-to-install version for applications without strict medium separation.

For detailed description of the mounting procedure refer to subchapter "*Mounting with a simple mounting flange*".

- Compression fittings from **SCHMIDT**[®] accessories:

SCHMIDT Technology offers four different compression fittings that are primarily designed for installation at pipes. They are also suitable for the installation on a wall if high mechanical stability is required or the measuring medium is under overpressure.

For detailed description of the mounting procedure refer to subchapter "*Mounting with a compression fitting*".

Direct mounting in a wall without a thread

This installation is not suitable for pressure-tight applications and requires access from both sides for operation.

- Drill a hole in the wall with 13 ... 14 mm diameter.
- Carefully insert measuring probe with attached protection cap into the hole so that the mounting block of the housing is in contact with the wall.
- Screw on the enclosed fastening nut by hand from the medium side, turn sensor into required position and tighten fastening nut by using wrench size 27) while holding up the housing on the mounting block by means of wrench size 30.
- Finally, remove protective cap from sensor tip.

Direct mounting in a wall with housing thread

In this case, the enclosure thread is screwed into a thread (G $\frac{1}{2}$) which has been cut directly into the wall (see Figure 3-2).

This method is suitable for high-pressure applications provided the required measures have been taken.



For measurements in media with overpressure: Switch system to depressurized state, seal the thread (e.g. with tape made of PTFE) and secure sensor against discarding.

Depending on whether the enclosed fastening nut can be used for locking or not, the rotation position can be adjusted:

Installation without lock nut:

- Carefully insert measuring probe with attached protective cap¹³ into the hole so that the mounting block of the enclosure is in contact with the wall.
- Screw in housing thread so that the mounting block is in contact with the wall.
- Tighten using the wrench size 30 on the mounting block by hand.
- Finally remove protective cap¹⁰.

The wall must be thick enough that the housing's thread does not protrude on side of the medium to avoid turbulences. The immersion length is determined by sensor length, the rotation position of the sensor cannot be corrected (see Figure 3-2).

Installation with a lock nut:

- Screw the enclosed fastening nut as far as possible onto the housing's thread.
- Carefully insert measuring probe with attached protective cap into the hole and screw in the housing's thread as far as required (min. 3 turns).
- Turn sensor housing into the required position, hold up at its mounting block by means of the wrench size 30 and lock the nut.
- Finally, remove protective cap.

The immersion depth is determined by probe length except for a few millimeters of locking tolerance, rotation position of the sensor is adjustable.

¹³ If the protective cap can be removed on the side of the medium; otherwise, remove before installation.

Direct mounting in a pipe

For installation in a pipe a connecting piece with suitable inner thread (G $\frac{1}{2}$) is normally welded, the immersion depth of the measuring probe can be adjusted to a certain extent over its length (see Figure 3-5).

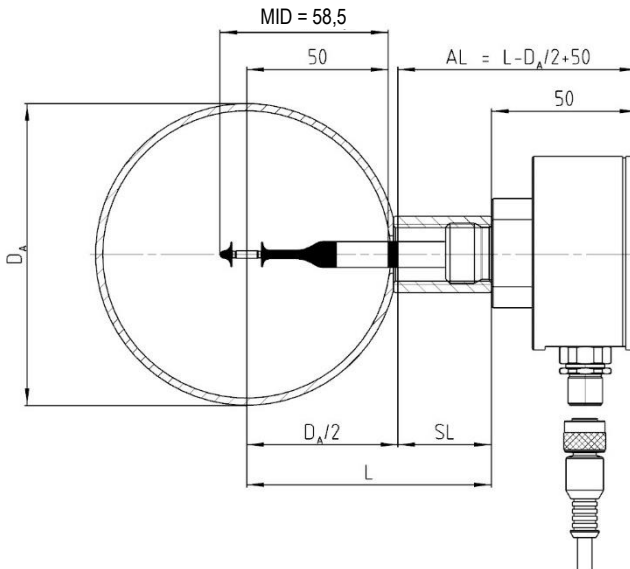

Figure 3-5

- L Probe length [mm]
- SL Length of weld-in sleeve [mm]
- AL Projecting length [mm]
- D_A Outer diameter of pipe [mm]
- MID Minimum immersion depth [mm]

This method is suitable for high-pressure applications provided the required safety measures are taken.



For measurements in media with overpressure:
Depressurize system, seal the thread (e.g. with tape made of PTFE) and install safety devices to secure against discarding.

Further mounting is performed according to the previous subchapter "*Direct mounting in a wall with a thread*".

Mounting with compression fitting

SCHMIDT Technology offers four types of compression fittings that differ in material (brass or stainless steel) and pressure tightness (atmospheric or suitable for 10 bar; for details refer to subchapter „Accessories“).

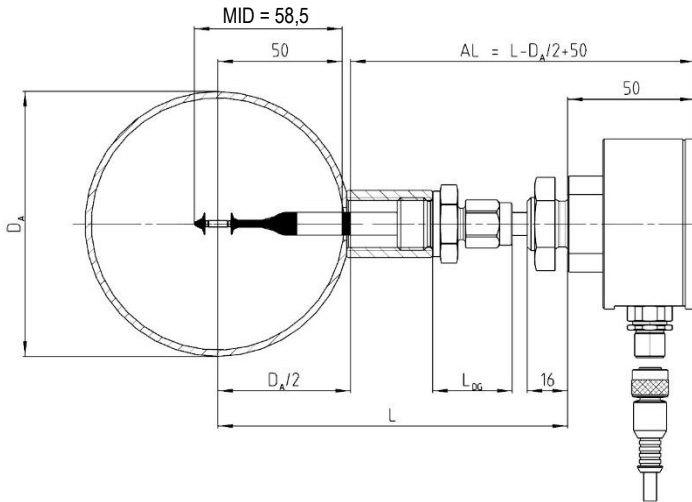

Figure 3-6

L	Probe length [mm]
AL	Projecting length [mm]
D_A	Outer diameter of pipe [mm]
MID	Minimum immersion depth [mm]
L_{DG}	Length of compression fitting [mm]

A compression fitting is installed using its external thread ($G\frac{1}{2}$). Typically, a sleeve¹⁴ with a matching inner thread is welded onto the borehole in the medium-guiding system wall as a connecting piece. In most applications, these are pipes which will be used for the description of the mounting procedure (see Figure 3-6).

¹⁴ Perfect for curved installation surfaces; also suitable for even surfaces.

Note:

- Passages in the following description that are indented with that kind of arrow on the left margin describe additional working steps for pressure-tight installation.



Depressurize system for measurements with overpressure media and mount pressure protection kit.

- Bore a mounting opening in a pipe wall.
- Weld connecting piece with an internal thread G½ in the centre above the mounting opening on the pipe.
Recommended length of connecting piece: 15 ... 40 mm
- Screw threaded part of compression fitting into connecting piece (wrench size 27).
 - Wrap thread using a common sealing tape, e.g. made of PTFE.
 - Plug holding bracket of pressure protection chain onto thread.
 - Observe correct seat and alignment of chain bracket.
- Unscrew spigot nut of the compression fitting (wrench size 17) to such an extent that sensor probe can be inserted without jamming.
- Remove protective cap from sensor tip, carefully insert probe into the guide in a coaxial direction and insert it so that the dumbbell-shaped head sleeve is placed at measuring position in the middle of the pipe.



Always avoid tilting of probe tip during insertion into the compression fitting.

- Tighten spigot nut slightly by hand so that sensor is fixed. Turn sensor manually at its housing into required position while maintaining immersion depth.
- Hold sensor and tighten spigot nut by turning the fork wrench (size 17) a quarter of a turn.
 - Shorten safety chain by removing superfluous chain links so that the chain is slightly tensioned after being locked at the housing. Finally, lock chain with a padlock.

Mounting with a simple mounting flange

This flange is not suitable for pressure-tight applications.

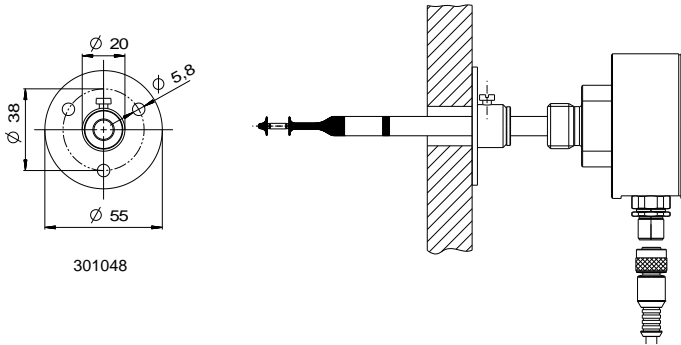

Figure 3-7

- Drill a hole with 10 ... 12 mm diameter into the wall.
- Align drilling pattern for fastening screws according to the required position of the locking screw.
- Screw down mounting flange.
- Remove protective cap and insert sensor probe carefully in a coaxial direction into mounting flange.
- Adjust immersion depth of probe, adjust sensor housing and fasten sensor by means of locking screw.

Mounting of remote version

The sensor probe of the remote version is mounted in the same way as the compact sensor by using optional accessories (compression fitting, mounting flange or wall mounting flange).

An angle bracket is included for attaching the sensor housing.

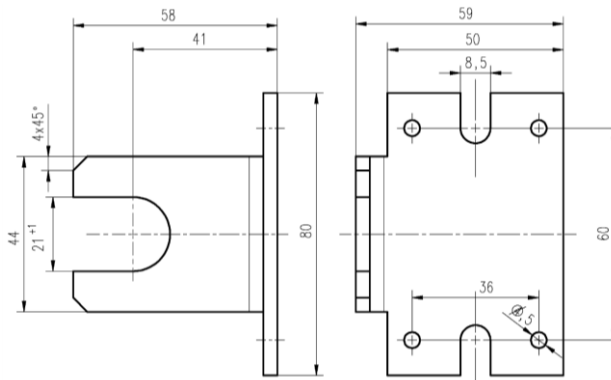
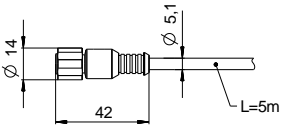
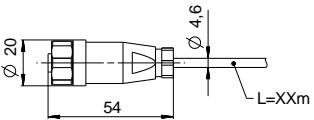
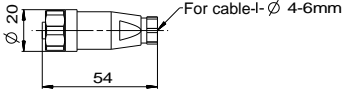
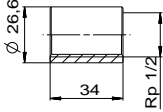
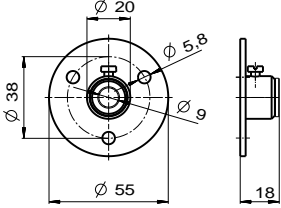
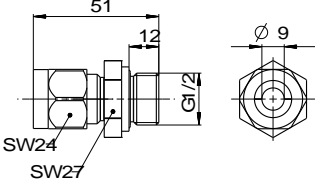

Figure 3-8

Accessories

A broad range of accessory is available for mounting the **SCHMIDT® Flow Sensor SS 20.500** to cover a wide range of applications (see Table 3).

Type / article No.	Drawing	Mounting
Connecting cable standard with fixed length: 5 m 523565		<ul style="list-style-type: none"> - Threaded ring, hexagon - Plug injection-molded - Material: Stainless steel PUR, PVC
Connecting cable standard with selectable length: xx m 523566		<ul style="list-style-type: none"> - Threaded ring, hexagon - Material: Stainless steel PA, PUR, PP Free of halogen¹⁵
Coupler socket VA thread locking system 523 562		<ul style="list-style-type: none"> - Threaded ring, hexagon - Material: Stainless steel Polyamide, PUR, PP - Connection of leads: Bolted (0.25 mm²)
Socket ¹⁶ a.) 524916 b.) 524882		<ul style="list-style-type: none"> - Internal thread G½ - Material: a.) Steel, black b.) Stainless steel 1.4571
Mounting flange 301048		<ul style="list-style-type: none"> - Immersion sensor - Wall - Fastening with screws - Material: Steel, galvanic Zn PTFE <p>Atmospheric pressure use!</p>
Compression fitting Brass 517206		<ul style="list-style-type: none"> - Immersion sensor - Pipe (typ.), wall - Screwing into a welding stud - Material: Brass PTFE, NBR <p>Atmospheric pressure use!</p>

¹⁵ According to IEC 60754

¹⁶ Must be welded.

<p>Compression fitting V4A</p> <p>532160</p>		<ul style="list-style-type: none"> - Immersion sensor - Pipe (typ.), wall - Screwing into a welding stud - Material: Stainless steel 1.4571 PTFE <p>Atmospheric pressure use!</p>
<p>Compression fitting Brass¹⁷</p> <p>a.) 524891 b.) 524919</p>		<ul style="list-style-type: none"> - Immersion sensor - Tube (typ.), wall - Screwing into a welding stud - Material: FKM a.) Brass b.) Stainless steel <p>Pressure-tight up to 10 bar!</p>
<p>Wall mounting flange</p> <p>520181</p>		<ul style="list-style-type: none"> - Immersion sensor - (plane) wall - Screw on with 2 screws - Material: Stainless steel 1.4401 PTFE, NBR <p>Atmospheric pressure use (pressure-tight ≤ 500 mbar)</p>

Table 3

Notes:

- The supplied connecting cables generally consist of media-resistant materials (thread ring made of stainless steel, sheathing and enclosure made of PUR).
- The connecting cable with fixed length is not free of halogen.
- The connecting cable with selectable length (lead insulation made of modified PP) as well as the coupler socket is free of halogen.
- All mounting fixtures fasten the sensor by means of frictional clamping. This enables stepless positioning of the sensor in the holder concerning its immersion depth and axial adjustment. Accordingly, positioning and alignment of the sensor tip in the flow field must be carried out with great care. Make sure to tighten fastening screw properly, especially for applications with overpressure.

¹⁷ Pressure protection kit included

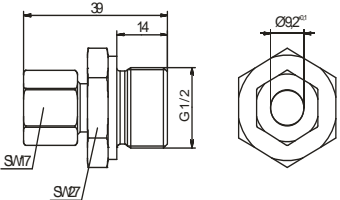
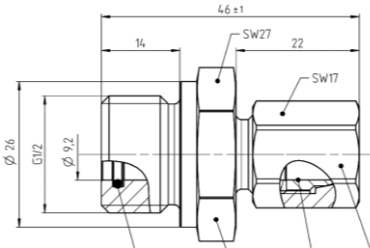
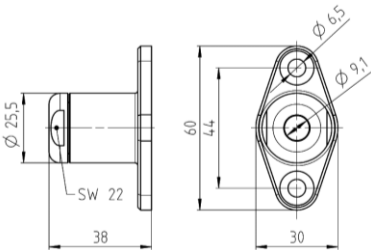
4 Electrical connection



During electrical installation ensure that no voltage is applied and inadvertent activation is not possible.

The sensor is equipped with a plug-in connector which is firmly integrated in its housing with following features:

Number of connection pins:	5
Type:	Male
Fastening of connecting cable:	M12 thread (spigot nut at the cable), A-coded
Type of protection:	IP67 (with screwed cable)
Model:	Binder, series 713
Pin numbering:	

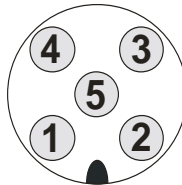

View on connector of sensor

Figure 4-1

Pin assignment of the plug-in connector is given in the following Table 4.

Pin	Designation	Function	Lead colour
1	Power	Operating voltage DC: $+U_B$ Operating voltage AC: U_{\sim}	brown
2	Analog T_M	Output signal: Temperature of medium	white
3	GND	Operating voltage DC: GND ($-U_B$) Operating voltage AC: U_{\sim}	blue
4	Analog w_N	Output signal: Standard flow velocity	black
5	AGND	Ground connection of analog outputs	gray

Table 4

The specified lead colours are valid if one of the **SCHMIDT**[®] connecting cables is used (see subchapter "Accessories").



The appropriate protection class III (SELV) respective PELV (according EN 50178) has to be considered.

Operating voltage

For proper operation the sensor requires DC or AC voltage with a nominal value of 24 V_(eff) with permitted tolerance of ±20 %.

Deviating values lead to deactivation of the measuring function or even to defects and, therefore, should be avoided. As far as it is functionally possible, the LED indication reports the faulty operational conditions (see *chapter 5 Signalling*).



Only operate sensor within the defined range of operating voltage (24 V DC / AC ± 20 %).

Undervoltage may result in malfunction; overvoltage may lead to irreversible damage.

The operating current of the sensor (including signal currents) is worst case¹⁸ less than 170 mA; typically, it is in the range of 50 to 100 mA.

Specifications for operating voltage apply for the connection at the sensor. Voltage drops generated due to line resistances must be considered by the customer.

Wiring of analog outputs

Both analog outputs, for flow and temperature, are designed as high-side driver featuring a permanent short-circuit protection against both rails of the operating voltage.

- Nominal operation

The load resistance R_L must be connected between the corresponding signal output and the electronic reference potential of the sensor (see Figure 4-2). In general, AGND should be selected as measuring reference potential. The supply line GND ($U_{B,DC}$) can also be used as reference potential; however, ground offset can cause significant measurement errors using the signal output mode "voltage".



In general, AGND should be selected as measuring reference potential for signal outputs.

- Use of only one analog output

It is recommended to connect the same resistance value to both analog outputs, even if only one of them is used. For example, if only the "flow" analog output is operated as current output with a resistance value of a few Ohms, it is recommended to connect the other analog output ("temperature") with the same resistance value or directly to AGND.

¹⁸ Including both signal outputs with 22 mA (maximum measuring values), operating voltage at minimum.

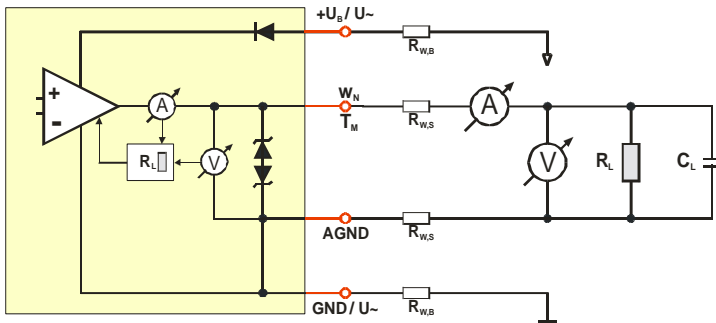

Figure 4-2

- Characteristics of analogue interfaces

In standard order configuration of the sensor, the analogue outputs operate in "Auto-U/I" mode. Depending on the value of the load resistance R_L the electronics switches automatically between its operation as voltage interface (mode: U) or current interface (mode: I), hence, the designation „Auto-U/I“. The switching threshold is within the range of $R_L = 500$ to 550Ω (for details refer to *chapter 5 Signalling*). However, a low resistance value in voltage mode may cause significant voltage losses in the connection cable via its line resistances $R_{W,S}$, which can lead to measurement errors.



For voltage mode it is recommended to use a measuring resistance of at least 10 k Ω .

Optionally, the sensor can also be ordered with current interfaces. The maximum load capacity is 10 nF.

- Short-circuit mode

In case of a short circuit against the positive rail of an operating DC voltage ($+U_B$) resp. against both rails during the positive AC half-cycle the signal output is switched off. Due to internal measuring resistances it is possible that an undefined current of up to 15 mA flows into the sensor output (referred to AGND).

In case of a short-circuit against the negative rail (GND) of a DC supply or against both rails during a negative AC half-cycle an output in Auto-U/I configuration switches to current mode (R_L is calculated for 0Ω) and provides the required signal current.

If the signal output is connected to $+U_{B,DC}$ or to one of the rails for AC voltage via a resistance, the value of R_L is calculated incorrectly which leads to false measurement values or cyclic switching of the signal modes with the frequency of the AC voltage.

5 Signalling

Light emitting diodes (LED)

The **SCHMIDT® Flow Sensor SS 20.500** has four Duo-LEDs¹⁹ (see Figure 5-1) which are indicating the flow velocity during error-free operation (bargraph modus) or signalling the error cause (see Table 5).

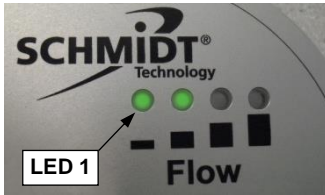

Figure 5-1

No.	State	LED 1	LED 2	LED 3	LED 4
1	Ready for operation & flow < 5 % ²⁰				
2	Flow > 5 %				
3	Flow > 20 %				
4	Flow > 50 %				
5	Flow > 80 %				
6	Flow > 100 % = overflow				
7	Sensor element defective				
8	Supply voltage too low				
9	Supply voltage too high				
10	Electronic temperature too low				
11	Electronic temperature too high				
12	Medium temperature too low				
13	Medium temperature too high				

Table 5



LED off



LED shines green



LED shines orange



LED flashes red (approx. 1 Hz)

¹⁹ Component with two separately controllable LEDs (red and green) that generate in combination the mixed color orange.

²⁰ „%“ of the end of measuring range

Analog outputs

- Switching characteristic Auto-U/I

Range of load resistance R_L	Signalling mode	Signalling range
≤ 500 (550) Ω	Current (I)	4 ... 20 mA
> 500 (550) Ω	Voltage (U)	0 ... 10 V

A hysteresis of approx. 50 Ω ensures a stable transition behavior (see Figure 5-2).

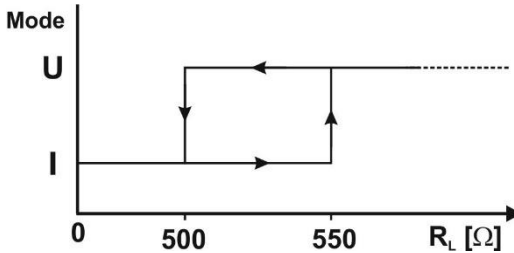

Figure 5-2

Depending on the provided output signal accuracy of the mode switching point detection can be decreased. Therefore, it is recommended to select the resistance in such a way that safe detection can be maintained ($< 300 \Omega$ for current mode and $> 1 \text{ k}\Omega$ for voltage mode).

To detect possible alternating load for an actual zero signal, the electronics generates test pulses that correspond to an effective value of approx. 1 mV. However, latest measuring devices may trigger in response to such a pulse in DC voltage measuring mode and display short-term measuring values of up to 20 mV. In this case it is recommended to install an RC filter at the measuring input with a time constant of 20 ... 100 ms.

- Error signalling

In current mode the interface outputs 2 mA²¹.

In voltage mode the output switches to 0 V.

- Representation of measuring range

The measuring range of the corresponding measuring value is mapped in a linear way to the signal range of its associated analog output specific for this mode.

For flow measurement the measuring ranges from zero flow to the selectable end of the measuring range $W_{N,max}$ (see Table 6).

²¹ In accordance with NAMUR specification.

Voltage mode (U)	Current mode (I)
$w_N = \frac{w_{N,max}}{10 V} \cdot U_{Out,w_N}$	$w_N = \frac{w_{N,max}}{16 mA} \cdot (I_{Out,w_N} - 4 mA)$

Table 6 Standard for representation of flow measurement

The measuring range of the medium temperature T_M is specified between -40 and $+85$ °C (see Table 7).

Voltage mode (U)	Current mode (I)
$w_N = \left(\frac{125}{10 V} \cdot U_{Out,T_M} - 40 \right) ^\circ C$	$w_N = \left[\frac{125}{16 mA} \cdot (I_{Out,T_M} - 4 mA) - 40 \right] ^\circ C$

Table 7 Standard for representation of medium temperature measurement

Note regarding commissioning:

The temperature output normally provides approx. 5 V resp. 12 mA because the typical prevailing room temperature of approx. 20 °C corresponds to about half of the measuring range.

- Exceeding measuring range of flow w_N
 Measuring values higher than $w_{N,max}$ are still output in a linear way up to 110 % of the signalling range (this corresponds to maximum output of 11 V resp. 21.6 mA, see images in Table 6). For higher flow velocity values the output signal remains constant.
 Error signalling does not take place because damage of the sensor is unlikely.
- Medium temperature T_M beyond specification range
 Operation beyond specified limits can lead to damage of the measuring probe and, therefore, is seen as a critical error. This leads to the following reaction depending on the temperature limit (also refer to images in Table 7):
 - Medium temperature below $T_{M,min} = -40\text{ °C}$:
 Analog output for T_M switches to error signalling (0 V resp. 2 mA)²². The measuring function of flow velocity is switched off; its analog output also reports an error (0 V resp. 2 mA).
 - Medium temperature above $T_{M,max} = +85\text{ °C}$:
 Up to 90 °C T_M is still output in a linear way (this corresponds to 10.4 V resp. 20.6 mA), to enable an overshooting of heating control. The flow velocity is measured and displayed further on.
 Above this critical limit²² flow measurement is switched off and its analog output signals error (0 V resp. 2 mA). The signal output for T_M jumps directly to its maximum values of 11 V resp. 22 mA which differs from standard error signalling.
 This prevents a problematic positive feedback in that case, that a heating control uses the temperature sensor of the flow sensor. Standard error signalling of 0 V (resp. 2 mA) could be identified by the control as a very low temperature of the medium, this would lead to further heating.

²² Switching hysteresis for the threshold is approx. 2 K.

6 Commissioning

Before switching on the **SCHMIDT® Flow Sensor SS 20.500** the following checks have to be carried out:

- Mechanical mounting:
 - Immersion depth of sensor probe and alignment of housing.
 - Tightening of fastening screw respective spigot nut.
 - Installation of pressure safety devices.



For measurements in media with overpressure check if fastening screw is tightened properly and pressure safety devices are installed.

- Connecting cable:
 - Proper connection in the field (switch cabinet or similar).
 - Tightness between sensor connector and connecting cable (flat seal must be inserted correctly into the female cable connector).
 - Tight fit of spigot nut on connecting cable connector at sensor housing.

After turning on the operating voltage, the sensor reports initialization by switching on all four LEDs simultaneously for one second at a time, sequentially in the colors red, orange and green.

If the sensor detects a problem during initialization, it reports the problem after initialization according to Table 5. An extensive overview of error causes and troubleshooting measures is given in Table 9.

If the sensor is in the correct operational state after initialization it switches into measuring mode. The indication of flow velocity (both LEDs and analog output) switches for a short period to maximum and settles after approx. 10 s at the rough measuring value. Correct measuring values can be expected after approx. 30 s if the sensor probe already has the medium temperature. Otherwise, the process will last longer until the probe has reached the medium temperature.

7 Information concerning operation

Ambient condition temperature

The **SCHMIDT® Flow Sensor SS 20.500** monitors the temperature of both medium and electronics. As soon as one limit of the specified temperature ranges is exceeded, the sensor switches off one or both measuring functions associated with the medium depending on the situation and report the corresponding error. As soon as proper operational conditions are restored, the sensor resumes normal function.

Even a short-term overshooting of the safety limit values can lead to permanent damage of the sensor which must be avoided by all means. On the other hand, falling below is less critical but leads to an increased brittleness of sensitive components, for example of the sensor tip or connecting cable.



Even short-term overshooting of operating temperatures can cause irreversible damage to the sensor.

Ambient condition pressure

The flow sensor **SS 20.500** exhibits a minor dependency on overpressure p_{op} close to zero flow. At $w_N = 0$ m/s the sensor signals with increasing overpressure an increasing flow $w_{N,Sensor,0,Op} > 0$ m/s in a proportional way. This deviation decreases rapidly with increasing flow and diminishes at $w_{N,Sensor,C}$ showing correct measurements with no further influence from pressure (see Table 8).

The residual dependence of the pressure can be calculated to:

$$w_{N,Sensor,0,Op} = 0.04 \frac{m/s}{bar} \cdot p_{Op}$$

$$w_{N,Sensor,C} = 2 \cdot w_{N,Sensor,0,Op}$$

p_{Op} [bar]	Sensor signal: $w_{N,Sensor}$ [m/s]							
	@ w_N [m/s]							
	0,0	0,1	0,2	0,3	0,4	0,6	0,8	1,0
0	0,00	0,00	0,20	0,30	0,40	0,60	0,8	1,0
2	0,08	0,09	0,20	0,30	0,40	0,60	0,8	1,0
4	0,16	0,18	0,26	0,31	0,40	0,60	0,8	1,0
6	0,24	0,26	0,34	0,39	0,44	0,60	0,8	1,0
8	0,32	0,35	0,42	0,47	0,52	0,62	0,8	1,0
10	0,40	0,44	0,50	0,55	0,60	0,70	0,8	1,0

Table 8 Pressure dependence of sensor signal near zero flow

Ambient condition medium

The **SCHMIDT® Flow Sensor SS 20.500** is especially suitable for impure gases that contain dust, non-abrasive particles or gaseous fractions such as vapors, oils or chemically aggressive components.

Deposits or other soiling must be detected during regular inspections and removed by cleaning because it can cause deviations in measurement results (see *chapter 8 Service information*).



Soiling or other deposits on the probe head cause false measurement results.

Therefore, the sensor must be checked for contaminations at regular intervals and cleaned if necessary.

The coated probe (coating versions: black PU-derivate or transparent Parylene) has particularly high chemical media resistance against organic solvents, acids and caustics in liquid or gaseous state, for example:

Acetone, ethyl acetate, methyl ethyl ketone, perchlorethylene, xylene, alcohols, ammonia, petrol, motor oil (50 °C), cutting oil (50 °C), sodium hydroxide, acetic acid, hydrochloric acid, sulphuric acid and more.

The suitability of the mentioned above or other similar chemicals must be checked in every individual case due to different ambient conditions.

Condensing liquid fractions in gases or even immersion into liquids do not damage the probe (as long as there is no damage due to corrosion or similar). However, the significantly higher heating capacity of liquids distort measuring results seriously (e.g. when immersing into water the flow indication goes to maximum) but after drying of the sensor tip normal measuring function is available again.



(Condensating) liquid on the measuring probe causes serious measurement deviations.

After drying the correct measuring function is restored.

Sterilization

Both uncoated and coated sensor can be sterilized during operation.

Alcohols (drying without leaving residues) and hydrogen peroxide²³ are approved and certified as disinfectants.

Other disinfectants must be checked by the customer if necessary.

²³ Use of hydrogen peroxide only with uncoated version.

8 Service information

Maintenance

Heavy soiling of the sensor tip may distort the measured value. Therefore, the sensor tip must be checked for soiling at regular intervals. The sensor can be cleaned as described below.

Cleaning of probe tip

To clean the sensor tip from dust or soiling move it carefully in warm water with a cleaning agent or other permitted cleaning fluids (e.g. alcohol). Persistent incrustations or gratings can be previously softened by prolonged immersion and then removed by means of a soft brush. Avoid applying force to the sensitive probe tip.



The sensor tip is a sensitive measuring system.
During manual cleaning proceed with great care.

Before putting it into operation again wait until the sensor tip is completely dry.

Troubleshooting

Possible errors (error images) are listed in the Table 9.

There is also a description of the way to detect an error. Furthermore, possible causes and measures to eliminate the error are listed.



Causes of any error signalling have to be eliminated immediately. Significant exceeding or falling below the permitted operating limits can result in permanent damage to the sensor.







Error image	Possible causes	Troubleshooting
 <p>No LED is shining Both signal outputs at zero</p>	<p>Problems with supply U_B:</p> <ul style="list-style-type: none"> ➤ No U_B available ➤ Wrong polarity of DC-supply ➤ $U_B < 15\text{ V}$ <p>Sensor is defective</p>	<ul style="list-style-type: none"> ➤ Plug-in connector screwed on correctly? ➤ Supply voltage connected? ➤ Voltage at sensor plug available (cable break)? ➤ Power supply large enough?
<p>Start sequence is repeated continuously (all LEDs flashing simultaneously red - yellow - green)</p>	<p>U_B unstable:</p> <ul style="list-style-type: none"> ➤ Power cannot supply switch-on current ➤ Other consumers overload power source ➤ Cable resistance too high 	<ul style="list-style-type: none"> ➤ Supply voltage at sensor stable? ➤ Power of supply unit sufficiently? ➤ Voltage losses over cable negligible?
	<p>Sensor element defective</p>	<p>Return sensor for repair</p>
	<p>Electronic temperature too low</p>	<p>Increase temperature of environment</p>
	<p>Electronic temperature too high</p>	<p>Decrease temperature of environment</p>
	<p>Medium temperature too low</p>	<p>Increase medium temperature</p>
	<p>Medium temperature too high</p>	<p>Reduce medium temperature</p>
<p>Flow signal w_N is too large / small</p>	<p>Measuring range too small / large I-mode instead of U-mode Measuring medium does not correspond to air Sensor head is soiled</p>	<p>Check sensor configuration</p> <p>Check measuring resistance Gas correction considered?</p> <p>Clean sensor tip</p>
<p>Flow signal w_N is fluctuating</p>	<p>U_B unstable Sensor tip is not in optimum position Let-in or let-out distance is too short Strong fluctuations of pressure or temperature</p>	<p>Check voltage supply Check installation conditions</p> <p>Check operating parameters</p>
<p>Analog signal in U-mode has offset or is noisy</p>	<p>Measuring resistance of signal output is at GND</p>	<p>Connect measuring resistance to AGND</p>
<p>Analog signal permanently at max.</p>	<p>Measuring resistance of signal output is at U_B (DC)</p>	<p>Connect measuring resistance to AGND</p>
<p>Analog signal switches between min. and max.</p>	<p>Measuring resistance of signal output is at GND_{AC}</p>	<p>Connect measuring resistance to AGND</p>

Table 9

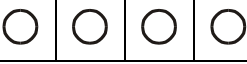
Transport / shipment of the sensor

Before transportation or shipment of the sensor the delivered protective cap must be placed on the sensor tip. Avoid soiling or mechanical stress.

Calibration

If the customer has made no other provisions, we recommend repeating the calibration at a 12-month interval. For this purpose, the sensor must be returned to the manufacturer:

Spare parts or repair

No spare parts are available, since a repair is only possible at the manufacturer's facility. In case of defects, the sensors must be sent in to the supplier for repair.

- **A completed declaration of decontamination must be attached.**

The form "Declaration of decontamination" is enclosed with the sensor and can also be downloaded from

www.schmidt-sensors.com or www.schmidttechnology.de

under the heading "Service & Support", "Sensorics".

If the sensor is used in systems important for operation, we recommend you to keep a replacement sensor in stock.

Test certificates and material certificates

Every new sensor is accompanied by a certificate of compliance according to EN 10204-2.1. Material certificates are not available.

Upon request, we shall prepare, at a charge, a factory calibration certificate, traceable to national standards.

9 Technical data

Measuring parameters	Standard velocity w_N of air, based on standard conditions 20 °C and 1013.25 hPa Temperature of medium T_M
Medium to be measured	Air or nitrogen, other gases on request
Measuring range w_N	0 ... 1 / 2.5 / 5 / 10 / 20 / 35 / 50 m/s
Lower detection limit w_N	0.06 m/s
Measuring accuracy w_N ²⁴ - Standard - Precision	$\pm(3\% \text{ of measured value} + [0.4\% \text{ of final value; min. } 0.02 \text{ m/s}])$ $\pm(1\% \text{ of measured value} + [0.4\% \text{ of final value; min. } 0.02 \text{ m/s}])$
Reproducibility w_N	$\pm 1\%$ of measured value
Response time (t_{90}) w_N	3 s (jump from 0 to 5 m/s)
Measuring range T_M	-40 ... +85 °C
Measuring accuracy T_M ($w_N > 1 \text{ m/s}$)	$\pm 1 \text{ K}$ (0 ... 30 °C); $\pm 2 \text{ K}$ in remaining intervals
Operating temperature	Medium: -40 ... +85 °C Electronics: -20 ... +70 °C
Humidity range	0 ... 95 % rel. humidity (RH), non-condensing
Max. operating pressure	Compact version: 10 bar (overpressure) Remote version: Atmospheric (< 1,300 hPa)
Operating voltage U_B	24 V _{DC/AC} $\pm 20\%$
Current consumption	Typ. 60 mA, max. 170 mA
Analog outputs - Type: Auto-U/I Voltage output Current output Switching hysteresis - Type: Current interface - Maximum load capacity	Flow velocity w_N , medium temperature T_M Automatic switching of signal mode based on load R_L 0 ... 10 V for $R_L \geq 550 \Omega$ 4 ... 20 mA for $R_L \leq 500 \Omega$ 50 Ω 4 ... 20 mA for $R_L \leq 500 \Omega$ 10 nF
Electrical connection	Plug-in connector M12, A-coded, 5-pin, male, screwed
Max. line length	Voltage: 15 m; current: 100 m
Type of protection	IP65 (housing) / IP67 (probe)
Protection class	III (SELV) or PELV (EN 50178)
Min. immersion depth	58 mm (lower values on request)
Length compact version	Probe: 100 / 150 / 350 mm; special: 100 ... 1000 mm
Length remote version	Probe: 161.5 mm Cable: 3 m; special: 1 ... 30 m (in steps of 1 m)
Materials	PBT, stainless steel 1.4404, aluminum anodized Coatings (optional): Polyurethane, Parylene
Weight	400 g max. (compact version, without connection cable)

²⁴ Under reference conditions

10 Declarations of conformity

SCHMIDT Technology GmbH herewith declares in its sole responsibility, that the product

SCHMIDT® Flow Sensor SS 20.500

Part-No. **521 501**

is in compliance with the appropriate



European guidelines and standards

and



UK statutory requirements and designated standards.

The corresponding declarations of conformity can be download from **SCHMIDT®** homepage:

www.schmidt-sensors.com

www.schmidttechnology.de



SCHMIDT Technology GmbH

Feldbergstraße 1
78112 St. Georgen
Germany

Phone +49 (0)7724 / 899-0

Fax +49 (0)7724 / 899-101

Email sensors@schmidttechnology.de

URL www.schmidt-sensors.com
www.schmidttechnology.de