

Simply a question of  
**better measurement**



**SCHMIDT® Flow Sensor  
SS 20.260  
Instructions for Use**

# SCHMIDT® Flow Sensor SS 20.260

## Table of Contents

1	Important information.....	3
2	Application range.....	4
3	Mounting instructions.....	4
4	Electrical connection.....	11
5	Signalization .....	12
6	Startup .....	14
7	Information concerning operation.....	15
8	Service information.....	16
9	Technical data .....	18
10	Declarations of conformity.....	19

Imprint:

Copyright 2021 **SCHMIDT Technology GmbH**

All rights reserved

Version: 508981.02J

Subject to modifications

# 1 Important information

The instructions for use contain all required information for a fast commissioning and a safe operation of the **SCHMIDT® Flow sensor SS 20.260**:

- These instructions for use must be read completely and observed carefully, before putting the unit into operation.
- Any claims under the manufacturer's liability for damage resulting from non-observance or non-compliance with these instructions will become void.
- Tampering with the device in any way whatsoever - with the exception of the designated use and the operations described in these instructions for use - will forfeit any warranty and exclude any liability.
- The unit is designed exclusively for the use described below (see *chapter 0*). In particular, it is not designed for direct or indirect protection of personal or machinery.
- **SCHMIDT Technology** cannot give any warranty as to its suitability for certain purpose and cannot be held liable for accidental or sequential damage in connection with the delivery, performance or use of this unit.

## Symbols used in this manual

The symbols used in this manual are explained in the following section.



**Danger warnings and safety instructions – read them carefully!**

Non-observance of these instructions may lead to injury of personnel or malfunction of the device.

## General note

All dimensions are indicated in mm.

## 2 Application range

The **SCHMIDT® Flow sensor SS 20.260** (article number: 506 690) is designed for stationary measurement of the flow velocity as well as the temperature of pure<sup>1</sup> air and gases under atmospheric pressure.

The sensor is based on the measuring principle of a thermal anemometer and measures the mass flow of the measuring medium as flow velocity which is output in a linear way as standard velocity<sup>2</sup>  $w_N$  (unit: m/s), based on standard conditions of 1013.25 hPa and 20 °C. Thus, the resulting output signal is independent of pressure and temperature of the medium to be measured. The sensor is designed for the use inside closed rooms and is not suitable for outdoor use.



When using the sensor outdoors, it must be protected against direct exposure to the weather.

## 3 Mounting instructions

### General information on handling

The **SS 20.260** is a precision instrument with high measuring sensitivity. In spite of the robust construction of the sensor tip soiling of the inner sensor elements can lead to distortion of measurement results (see also *chapter 8*). During procedures that could yield soiling like transport, mounting or dismounting of the sensor it is recommended to place the enclosed **SCHMIDT Technology** protective cap on the sensor tip and remove it only during operation.



During processes with enhanced risks of soiling such as transport or mounting the protective cap should be placed onto the sensor tip.

### General installation conditions

The sensor measures the flow speed correctly only in the direction given on the housing and sensor head (arrow). Make sure that the sensor is adjusted in flow direction (see Figure 1); a tilting of up to  $\pm 3^\circ$  is allowed<sup>3</sup>.



The sensor measures unidirectional and must be adjusted correctly relative to the flow direction.

---

<sup>1</sup> No chemically aggressive parts / abrasive particles. Check suitability in individual cases.

<sup>2</sup> Corresponds to the actual flow velocity under standard conditions.

<sup>3</sup> Measurement deviation < 1 %

The sensor should preferably be installed in horizontally positioned pipes. A sensor mounted in opposite direction of the flow direction leads to wrong measuring values (too high).



Due to system characteristics the lower measuring range limit of the sensor is 0.2 m/s.



At lower flow velocities (< 2 m/s), the measured medium temperature is too high.

The center of the chamber head is the actual measuring point of the flow measurement and must be placed in the flow as advantageous as possible, for example in the middle of a pipe (see Figure 1). Therefore, this point is also used for specification of probe length L (see Figure 2).

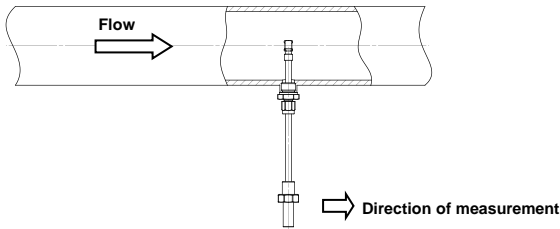

Figure 1 Positioning in a pipe



Always position the sensor head, if possible, in the middle of the pipe or shaft.

## Installation with low disturbance

Local turbulences of the medium can cause distortion of measurement results. Therefore, appropriate mounting conditions must be guaranteed to ensure that the gas flow is supplied to the sensor in a quiet state and low in turbulence to maintain the accuracy specified (see *chapter 9*).



Correct measurements require quiet flow, as low-turbulence as possible.

An undisturbed flow profile can be achieved if a sufficiently long distance in front of (run-in distance) and behind (run-out distance) the sensor installation site (see Figure 2) is held absolutely straight and without disturbances (such as edges, seams, bends etc.). It is also necessary to pay attention to the design of the run-out distance because disturbances also generate turbulences **against** the flow direction.

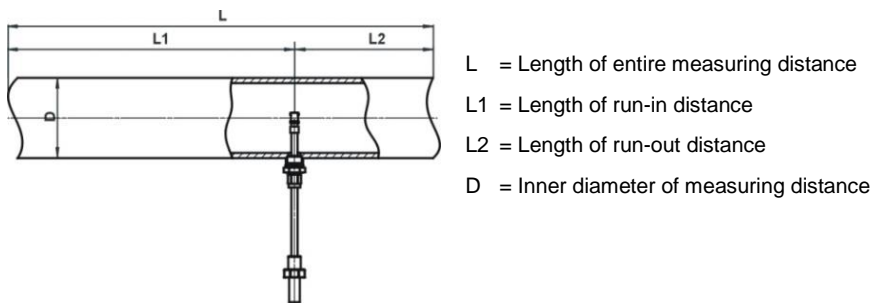

**Figure 2**

The following Table 1 shows the required straight conduit lengths depending on the pipe's inner diameter "D" and the different disturbance causes.

Flow obstacle upstream of the measuring distance	Minimum length of distance	
	Run-in L1	Run-out L2
Light bend (< 90°)	10 x D	5 x D
Reduction / expansion / 90° bend or T-junction	15 x D	5 x D
Two 90° bends in one plane (2-dimensional)	20 x D	5 x D
Two 90° bends (3-dimensional change in direction)	35 x D	5 x D
Shut-off valve	45 x D	5 x D

**Table 1**

This table lists the **minimum values** required in each case. If it is not possible to observe the specified abatement distances, increased deviations of the measurement results are to be expected or it is necessary to take additional measures<sup>4</sup>. The profile factors specified in Table 2 may become void by the use of flow rectifiers.

## Calculation of volume flow

If the cross section area of the pipe is known, the output signal of the flow speed  $w_N$  can be used to calculate the standard volumetric flow of the medium. By means of a correction factor  $PF^5$ , which depends on the pipe diameter  $D$  the measured value can be converted to an averaged flow velocity  $\overline{w_N}$  which is constant over the whole pipe cross-section.

Thus, it is possible to calculate the standard volumetric flow of the medium using the measured standard flow velocity in a pipe with known inner diameter:

<sup>4</sup> Alternatively, flow rectifiers could be used, e.g. honeycombs made of plastic or ceramics.

<sup>5</sup> Considers the flow profile and sensor obstruction.

$$A = \frac{\pi}{4} \cdot D^2$$

$$\bar{w}_N = PF \cdot w_N$$

$$\dot{V}_N = \bar{w}_N \cdot A \cdot 3600$$

$D$  Inner diameter of pipe [m]

$A$  Cross-section area of pipe [m<sup>2</sup>]

$w_N$  Flow velocity in the middle of the pipe [m/s]

$\bar{w}_N$  Average flow velocity in the pipe [m/s]

$PF$  Profile factor (for pipes with circular cross-sections)

$\dot{V}_N$  Standard volumetric flow [m<sup>3</sup>/h]

Table 2 lists profile factors and volume flow measuring ranges (with certain sensor measuring ranges) for standard pipe diameters.

Diameter of measuring pipe				Profile faktor PF	Measuring range of volumetric flow [m <sup>3</sup> /h]			
Nominal size	Norm value		Inner [mm]		Min. @ 0.2 m/s	@ sensor measuring range [m/s]		
	DN	[inch]				2.5 m/s	20 m/s	50 m/s
25	25	1	26.0	<b>0.796</b>	0.30	3.80	30.4	76.1
			32.8	<b>0.796</b>	0.48	6.05	48.4	121
		1 1/4	36.3	<b>0.770</b>	0.57	7.17	57.4	143
40	40	1 1/2	39.3	<b>0.748</b>	0.65	8.17	65.3	163
			43.1	<b>0.757</b>	0.80	9.94	79.5	199
			45.8	<b>0.763</b>	0.91	11.3	90.5	226
50	50	2	51.2	<b>0.772</b>	1.14	14.3	114	286
			57.5	<b>0.777</b>	1.45	18.2	145	363
65	65	2 1/2	70.3	<b>0.786</b>	2.20	27.5	220	549
			76.1	<b>0.792</b>	2.59	32.4	259	648
80	80	3	82.5	<b>0.797</b>	3.07	38.3	307	767
100	100	4	100.8	<b>0.804</b>	4.62	57.7	462	1.155
125	125	5	125.0	<b>0.812</b>	7.17	89.7	717	1.794
150	150	6	150.0	<b>0.817</b>	10.4	130	1.040	2.599
180			182.5	<b>0.825</b>	15.5	194	1.554	3.885
200	200	8	206.5	<b>0.829</b>	20.0	250	1.999	4.998
	250	10	260.4	<b>0.835</b>	32.0	400	3.202	8.004
300	300	12	309.7	<b>0.840</b>	45.6	570	4.556	11.390
	350	14	339.6	<b>0.842</b>	54.9	686	5.491	13.728
400	400	16	389	<b>0.845</b>	72.2	903	7.223	18.058
450	450	18	437	<b>0.847</b>	91.5	1.143	9.147	22.867
500	500	20	486	<b>0.850</b>	114	1.419	11.353	28.383
600	600	24	585	<b>0.854</b>	165	2.066	16.527	41.317
700	700	28	684	<b>0.857</b>	227	2.834	22.673	56.683
800	800	32	783	<b>0.859</b>	298	3.723	29.781	74.452
900	900	36	882	<b>0.862</b>	379	4.740	37.920	94.800
1000	1000	40	980	<b>0.864</b>	469	5.865	46.923	117.308

Table 2

**SCHMIDT Technology** provides a convenient calculation tool to compute flow velocity or volume flow in pipes (circular or rectangular) for all its sensor types and measuring ranges on its homepage:

[www.schmidt-sensors.com](http://www.schmidt-sensors.com) or [www.schmidttechnology.de](http://www.schmidttechnology.de)

## Mounting in a wall

The housing has an external thread M18 x 1 (19 mm long) for direct mounting on or in the medium separating wall. Its advantage lies in the simplicity of installation without special accessories; however, the probe length defines the immersion depth in this case and this method requires access from both sides for operation:

- Drill a bore in the wall with 13 ... 14 mm diameter.
- Carefully insert measuring probe with an attached protection sleeve into the bore so that the mounting block of the enclosure is in contact with the wall.
- Screw on the enclosed fastening nut by hand on the medium side, turn sensor into required position and tighten fastening nut (SW22) while holding up the enclosure on the mounting block by means of SW30.



Angular deviation should not be greater than  $\pm 3^\circ$  relative to flow direction.

- Check the set angular position carefully, for example by means of a spirit level at the octagonal part of the sensor enclosure.
- Finally, remove protective cap from sensor tip.



## Mounting with a compression fitting

The sensor is installed using a special compression fitting (517206). Normally, a sleeve is welded as a connecting piece onto a bore in the medium-guiding pipe, in which the external thread ( $G\frac{1}{2}$ ) of the compression fitting is screwed (see Figure 3).

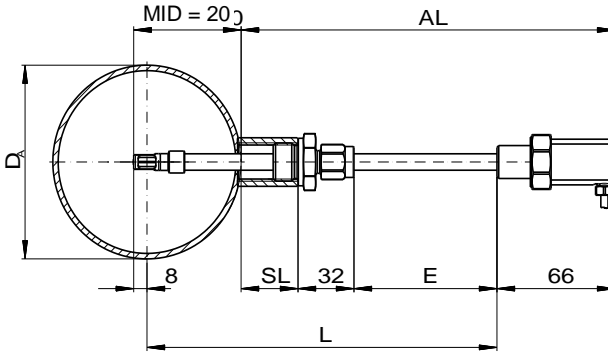

Figure 3

$L$	Sensor length [mm]	$D_A$	Outer diameter of the pipe [mm]
$SL$	Length of the weld-in sleeve [mm]	$E$	Sensor tube setting length [mm]
$AL$	Projecting length [mm]	$MID$	Minimum immersion depth [mm]

- Bore a mounting opening in a pipe wall.
- Weld connecting piece with an internal thread  $G\frac{1}{2}$  resp.  $Rp\frac{1}{2}$  centered above the mounting opening of the pipe.  
Recommended length of sleeve: 15 ... 40 mm
- If necessary wrap thread of compression fitting with common sealing tape, for example made of PTFE.
- Screw thread of compression fitting by hand into connecting piece then tighten it firmly with a fork wrench (SW27).
- Remove spigot nut of compression fitting and extract both seal halves.
- Remove protective cap from sensor tip and attach spigot nut on sensor probe.
- Insert probe in threaded part of compression fitting, attach seal halves and screw on spigot nut manually to such an extent that the sensor probe can be inserted without jamming.
- In case of a longer sensor probe push it partly into the pipe as required.



Always avoid bending of the probe tube during screwing.

- Carefully slide probe so that the center of the chamber head is placed at the optimum measuring position in the middle of the pipe.
- Tighten spigot nut slightly by hand so that sensor is fixed.
- Adjust sensor manually at its enclosure into required measuring direction and precise position while maintaining immersion depth.
- Hold sensor and tighten spigot nut by turning the fork wrench (SW17) a quarter of a turn.  
Recommended torque: 10 ... 15 Nm
- Check the set angular position carefully, for example by means of a spirit level at the octagonal part of the sensor enclosure.



Angular deviation should not be greater than  $\pm 3^\circ$  relative to the ideal measuring direction. Otherwise, the measurement accuracy may be affected.

- In case of wrong adjustment, the compression fitting has to be loosened and the alignment procedure must be repeated.

## Mounting accessories

Type / art. no.	Drawing	Mounting
Clamp <sup>6</sup> a.) 524 916 b.) 524 882		<ul style="list-style-type: none"> <li>- Internal thread Rp<math>\frac{1}{2}</math></li> <li>- Material: a.) Steel, black b.) Stainless steel 1.4571</li> </ul>
Compression fitting 517 206		<ul style="list-style-type: none"> <li>- Immersion sensor</li> <li>- Pipe (typ.), wall</li> <li>- Screwing into a welding stud</li> <li>- Material: Brass PTFE, NBR</li> <li>- Atmospheric pressure use!</li> </ul>

**Table 3**

<sup>6</sup> Must be welded.

## 4 Electrical connection

The sensor is equipped with a 4-pin cable firmly fixed to the sensor enclosure (pin assignment refers to Table 4).

Wire color	Designation	Function
Brown (BR)	Power	Operating voltage: +U <sub>B</sub>
White (WH)	GND	Operating voltage: Ground
Yellow (YE)	Analog w <sub>N</sub>	Output signal: Flow velocity
Green (GN)	Analog T <sub>M</sub> or AGND	Output signal: Temperature of medium or Ground connection of analog output

Table 4



During electrical installation ensure that no voltage is applied and inadvertent activation is not possible.

The cable has a standard length of 2 m, but lengths of 3 up to 100 m can be ordered optionally.

### Operating voltage

For proper operation the sensor requires DC voltage with a nominal value of 24 V with permitted tolerance of  $\pm 10\%$ . It is protected against a polarity reversal; typical operating current is 40 mA, at maximum 60 mA<sup>7</sup>.



Only operate sensor within the defined range of operating voltage (24 V DC  $\pm 10\%$ ).

Undervoltage may result in malfunction; overvoltage may lead to irreversible damage to the sensor.

The specifications for the operating voltage are valid for the internal connection of the sensor. Voltage drops generated due to cable resistances must be considered by the customer.

### Analog outputs

The basic sensor variant ("-1"), which measures only flow velocity, can be ordered with voltage<sup>8</sup> (0 ... 10 V) or current interface (4 ... 20 mA). The enhanced version ("-2") with an additional analog output for signaling medium temperature comes with 2 current interfaces. Either type of analog output is short-circuit protected against both rails of the operating voltage U<sub>B</sub>.

<sup>7</sup> Both signal outputs 22 mA (maximum measuring values), minimum operating voltage.

<sup>8</sup> It is recommended, to use AGND as measuring reference potential for voltage output.

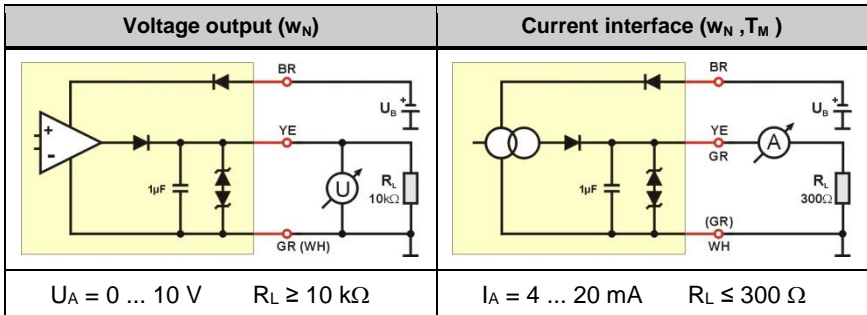

**Figure 4**

The apparent ohmic resistance  $R_L$  must be connected between the signal output and GND (see Figure 4).

Load capacity  $C_L$  is limited to a maximum of 10 nF.

## 5 Signalization

### Light emitting diodes

The sensor is equipped with 2 light emitting diodes (LED) indicating its functional state.



**Figure 5**

Operating state	LED 1	LED 2
Supply voltage: none, wrong polarity, too low	○	○
Sensor ready for operation	●	○
Supply voltage beyond specification range <i>or</i> Medium temperature beyond specification range	◐	○
Sensor defective	●	◑

**Table 5**

○ LED off

● LED on: green

◐ LED flashes (approx. 2 Hz): green

◑ LED flashes (approx. 2 Hz): red

## Analog outputs

- Error signaling

In current mode the interface delivers 2 mA<sup>9</sup>.

In voltage mode the output switches to 0 V.

- Representation of flow velocity

The measuring range of the corresponding measuring value is mapped in a linear way to the signaling range of its analog output.

For flow measurement the measuring range reaches from zero to the selectable end of the measuring range  $w_{N,max}$  (= 100 % in Figure 6). A higher flow up to 110 % of range (= 11 V or 21.6 mA) is still output in a linear way, moreover the signal remains constant.

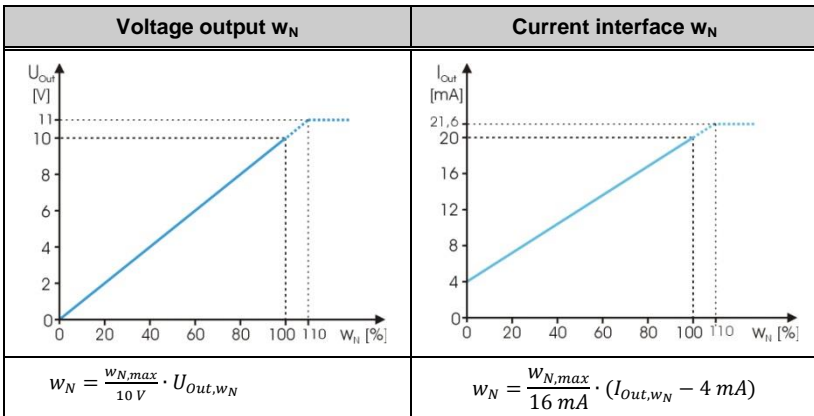

Figure 6 Representation for flow velocity

- Representation of medium temperature

The measuring range of the medium temperature is -20 to +120 °C (Figure 7). Falling below this temperature is still output in a linear way down to -30 °C (3 mA), going deeper the signal remains constant. An exceeded temperature is output linearly up to +130 °C (21.2 mA), moreover this output remains constant.



Even short-term overshooting of the operating medium temperature can cause irreversible damage of the sensor.



For a correct temperature measurement, the flow velocity on the sensor head must be > 2 m/s. An excessive temperature value is output if flow velocity is < 2 m/s.

<sup>9</sup> In accordance with NAMUR specification.

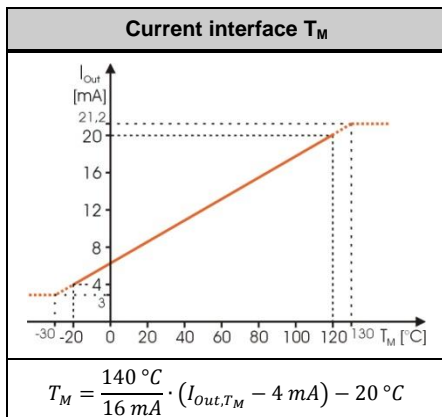

**Figure 7 Representation for medium temperature**

## 6 Startup

Prior to switching on the **SCHMIDT® Flow sensor SS 20.260**, the following checks have to be carried out:

- Immersion depth of the sensor probe and alignment of the housing.
- Tightening of the fastening screw of the compression fitting.
- Correct electrical connection in the field (switch cabinet or similar).



Prior to startup the sensor check mounting and electrical connection.

Five seconds after switch-on the sensor is ready for operation. If the sensor has another temperature than the ambient, this time is prolonged until the sensor has reached its ambient temperature.

If the sensor has been stored at very cold conditions, before commissioning you have to wait until the sensor and its housing have reached ambient temperature.

## 7 Information concerning operation



Soiling or other gratings on the sensor cause distortions of measurements.

Therefore, the sensor must be checked for soiling at regular intervals and cleaned if necessary.



(Condensing) liquid on the sensor causes serious measurement distortions.

After drying the correct measuring function is restored.

### Eliminating malfunctions

The following Table 6 lists possible errors (error images). A description of the way to detect errors is given. Furthermore, the possible causes and measures to be taken to eliminate errors are listed.

Error image	Possible causes	Troubleshooting
 $I_{WN}, I_{TM} = 0 \text{ mA}$	Problems with supply voltage $U_B$ : ➤ No $U_B$ available ➤ $U_B$ has wrong polarity ➤ $U_B < \text{approx. } 6.5 \text{ V}$  Sensor defective	➤ Sensor cable connected correctly? ➤ Supply voltage connected to control? ➤ Supply cable broken? ➤ Power supply unit large enough?
 $I_{WN}, I_{TM} = 2 \text{ mA}$	Sensor element defective	Send in sensor for repair
 $I_{WN}, I_{TM} = 2 \text{ mA}$	Operating voltage beyond specification range (too low / high) Medium temperature beyond specification range (too low / high)	Check operating voltage and set it correctly Check medium temperature and set it correctly
Flow signal $w_N$ is too large / small	Measuring range too small /large  Medium is not air Sensor element soiled Sensor installed in opposite direction to flow direction	Check sensor configuration Check measuring resistance Is foreign gas factor correct? Clean sensor tip Check installation direction
Flow signal $w_N$ is fluctuating	$U_B$ unstable Mounting conditions: ➤ Sensor head is not in optimal position ➤ Run-in/run-out distance is too short Strong fluctuations of pressure or temperature	Check voltage supply Check mounting conditions  Check operating parameters

Table 6

## 8 Service information

### Maintenance

Soiling of the sensor head may lead to distortion of the measured value. Therefore, the sensor head must be checked for contamination at regular intervals. If contaminations are visible, the sensor can be cleaned as described below.

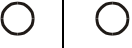
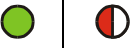
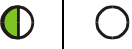
### Cleaning of sensor head

If the sensor head is soiled or dusty, it must be cleaned carefully by means of compressed air.



The sensor head is a sensitive measuring system. During manual cleaning proceed with great care.

In case of persistent deposits, the sensor chip as well as the interior of the chamber head can be cleaned carefully by using residue-free drying alcohol (e.g. isopropyl alcohol) or soapy water with special cotton swabs.



Figure 8 Suitable cotton swabs with small cleaning pads

For this purpose cotton swabs that have small, soft cotton pads are suitable, e.g. type "SP4" of the brand "CONSTIX Swabs" of the manufacturer "CONTEC" (see Figure 8). The flat, narrow side of the pads fit just between chamber head wall and sensor chip and therefore exerts a controlled, minimal pressure on the chip. Conventional cotton swabs are too big and therefore can break the chip.





Under no circumstances do attempt to pressurize the chip with greater force (e.g. by swabs with thick head or lever movements with its stick).

Mechanical overloading of the sensor element can lead to irreversible damage.

The sticks must be moved only with great care parallel to the chip surface back - and - forth to rub off the pollution. If necessary, several cotton swabs have to be used.

Before putting it into operation again, wait until the sensor head is completely dried. The drying process can be accelerated by gently blowing

If this procedure does not help, the sensor must be sent to **SCHMIDT Technology** for cleaning or repair.

## **Transport / shipment of the sensor**

Before transport or shipment of the sensor, the delivered protective cap must be placed onto the sensor tip. Avoid soiling or mechanical stress.

## **Calibration**

If the customer has made no other provisions, we recommend repeating the calibration at a 12-month interval. To do so, the sensor must be sent in to the manufacturer.

## **Spare parts or repair**

No spare parts are available, since a repair is only possible at the manufacturer's facilities. In case of defects, the sensor must be sent in to the producer for repair.

If the sensor is used in systems important for operation, we recommend you to keep a replacement sensor in stock.

## **Test certificates and material certificates**

A certificate of compliance according to EN 10204-2.1 accompanies every new sensor. Material certificates are not available.

Upon request, we shall prepare, at a charge, a factory calibration certificate, traceable to national standards.

## 9 Technical data

Measuring parameters	Standard velocity $w_N$ of air, based on standard conditions 20 °C and 1013.25 hPa Medium temperature $T_M$
Medium to be measured	Air or nitrogen, other gases on request
Measuring ranges <sup>10</sup> $w_N$	0 ... 10 / 20 / 40 / 50 / 60 m/s
Lower detection limit $w_N$	0.2 m/s
Measuring accuracy <sup>11</sup> $w_N$ - Standard - Precision	$\pm(5\%$ of measured value + [0.4 % of final value; min. 0.02 m/s]) $\pm(3\%$ of measured value + [0.4 % of final value; min. 0.02 m/s])
Reproducibility $w_N$	$\pm 1.5\%$ of measured value
Response time ( $t_{90}$ ) $w_N$	3 s (jump of $w_N$ from 5 to 0 m/s)
Temperature gradient $w_N$	< 8 K/min (at $w_N = 5$ m/s)
Measuring range $T_M$	-20 ... +120 °C
Measuring accuracy $T_M$ ( $w_N \geq 2$ m/s)	$\pm 1$ K ( $T_M = 0 \dots 40$ °C) $\pm 2$ K (remaining measuring range of $T_M$ )
Operating temperature - Medium - Electronics	-20 ... +120 °C 0 ... +70 °C
Humidity range	0 ... 95 % rel. humidity (RH), non-condensing
Operating pressure	Atmospheric (700 ... 1,300 mbar)
Operating voltage $U_B$	24 V <sub>DC</sub> $\pm$ 10 % (reverse voltage protected)
Current consumption	Typ. < 40 mA, 60 mA max.
Analog outputs - Voltage output - Current output - Maximum load capacity	1 or 2 pcs. (short-circuit protected) 0 ... 10 V ( $R_L \geq 10$ k $\Omega$ ) 4 ... 20 mA ( $R_L \leq 300$ $\Omega$ ) 10 nF
Electrical connection	Non-detachable connecting cable, pigtail <sup>12</sup> , 4-pin, length 2 m Special lengths: 3 ... 100 m (in steps of 1 m)
Maximum cable length	Voltage signal: 15 m, current signal: 100 m
Type of protection	IP54 (enclosure), IP65 (probe)
Protection class	III (SELV) or PELV (according EN 50178)
Mounting tolerance	$\pm 3^\circ$ relative to flow direction
Min. tube diameter	DN 25
Mounting	Thread M18 x 1 at sensor enclosure, accessories (option)
Installation length	50 / 100 / 200 / 350 / 500 mm
Weight	200 g max.

**Table 7**

<sup>10</sup> Measuring ranges of 50 m/s and 60 m/s only for variant "2".

<sup>11</sup> Under conditions of the reference.

<sup>12</sup> With cable end sleeves

## 10 Declarations of conformity

**SCHMIDT Technology GmbH** herewith declares in its sole responsibility, that the product

### **SCHMIDT® Flow Sensor SS 20.260**

Part-No. **506 690**

is in compliance with the appropriate



European guidelines and standards

and



UK statutory requirements and designated standards.

The corresponding declarations of conformity can be download from **SCHMIDT®** homepage:

[www.schmidt-sensors.com](http://www.schmidt-sensors.com)

[www.schmidttechnology.de](http://www.schmidttechnology.de)



**SCHMIDT Technology GmbH**

Feldbergstraße 1  
78112 St. Georgen  
Germany

Phone +49 (0)7724 / 899-0

Fax +49 (0)7724 / 899-101

Email [sensors@schmidttechnology.de](mailto:sensors@schmidttechnology.de)

URL [www.schmidt-sensors.com](http://www.schmidt-sensors.com)