

Pneumatic Presses and Hydropneumatic Presses

Direct Acting Presses, Toggle Presses,
Force / Stroke Monitoring



SCHMIDT® PneumaticPress

Maximum pressing force from 1.6 kN to 60 kN

The **SCHMIDT® PneumaticPress** range builds on a modular concept and can generate up to 60 kN. They are ideally suited for joining, assembly and forming applications.

With the addition of the **SCHMIDT® PressControl 75** or **700** and the optional process monitoring, these presses become EC type-approved, CE-conformed workstations. Therefore these press systems can be used in either single cycle or automatic mode.

The application determines the selection of the press system. Consideration is given to the flexible design of the assembly location, taking into account the ergonomic and safety aspects. These characteristics are achieved by means of a finely adjusted, modular type product range. The efficiency and increased process reliability of these press systems have been proven many times, in single applications, semi-automated assembly systems and have been integrated into automated production lines.



SCHMIDT® PneumaticPress

Example of a system design with a direct acting press

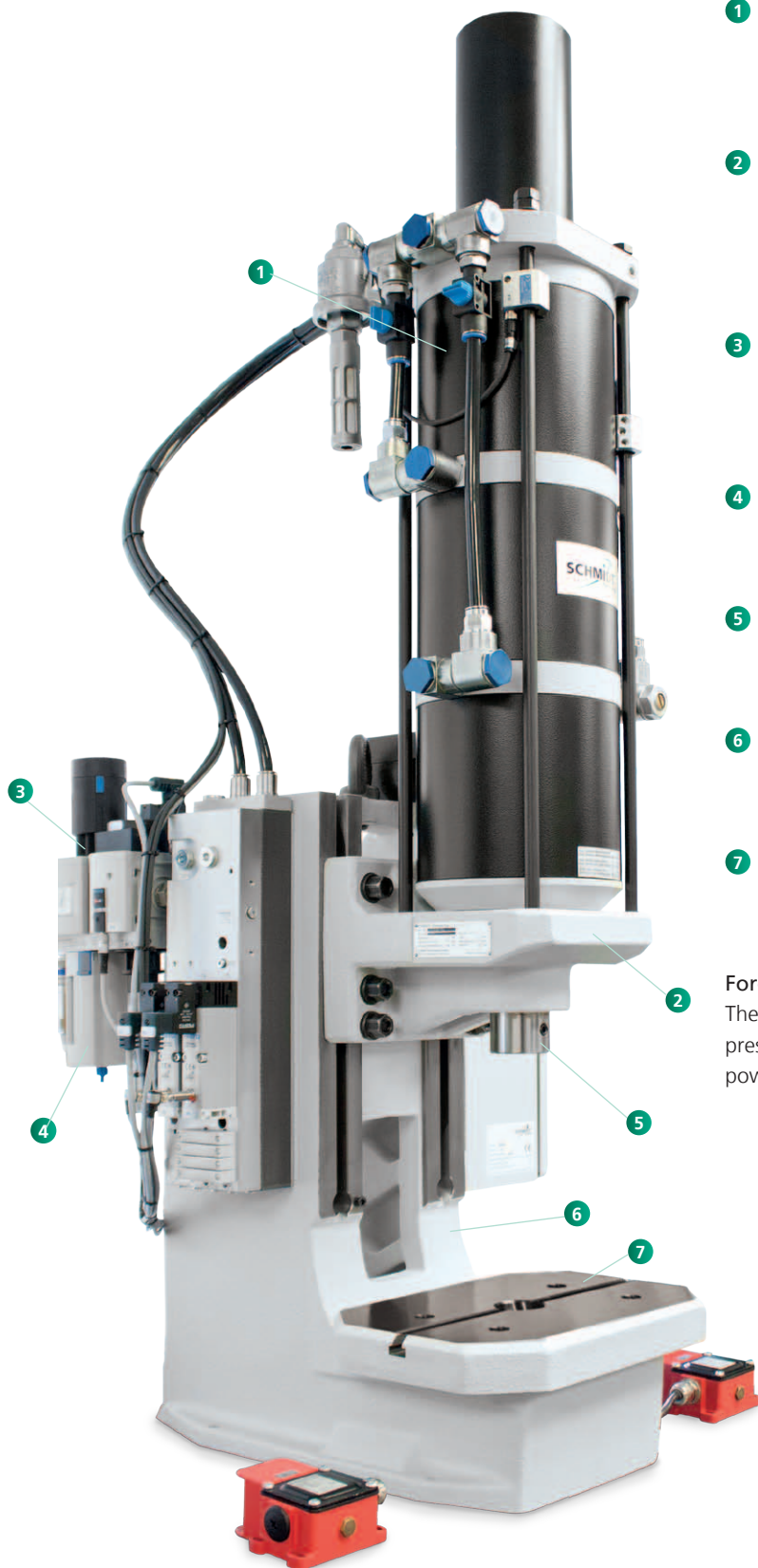

1 Cylinder unit

Maintenance-free specially developed for the assembly technology; with flow control for speed regulation of the down-stroke.

2 Press Head unit

Modular design allows for quick and accurate height adjustment when installed on our column or the system can be easily integrated, in any orientation, to an automated press solution.

3 Pneumatic control package

Two-channel pneumatic package (as shown) is based on a modular valve block, designed to operate with filtered, non-lubricated air, supply pressure range of 3 – 6 bar.

4 Force control

The force output can easily be controlled via a regulator and pressure gauge.

5 Ram

With precision bore for tool holding and built-in, adjustable stop.

6 Frame

Robust design with precision machined keyway for press head alignment.

7 Fixture mounting plate

With precision T-slot and precision bore for tool location.

Force output preselector (optional)

The press force output can easily be controlled via a separate pressure regulator and pressure gauge. The pressure for the power stroke can be reduced to 1 bar

SCHMIDT® PneumaticPress

Principle of operation

Functional description using a 3-chamber pneumatic cylinder – as an example.

In working stroke, three pistons **7** connected by the piston rod **6** are pressurized with compressed air via the air connection **1** and move downward. The air below the pistons exhausts from the cylinder chambers via the depressurized connection **2** and the breather vents **3** and **4**. The ram **5** extends up to the maximum working stroke.

In return stroke, the upper cylinder chambers are depressurized via the connection **1** and only the bottom piston is pressurized with compressed air via the air connection **2**. Ambient air enters in both remaining cylinder chambers via the breather vents **3** and **4**. The ram with the three pistons moves upward.

This construction has the same effect as a parallel connection of three cylinders. Thus, a powerful working stroke is achieved with a compact design as well as an economic use due to the low air consumption in the return stroke.

The stroke can be limited by setting the Stroke Limit Block **8** to an approximate, desired position. The gap between Stroke Limit Block and Stroke Fine Adjustment **9** now determines the maximum stroke that the ram can travel. In order to fine-tune this stroke, fine adjustment nut **9** can be adjusted.

All direct acting presses have a built-in permanent magnet **10**. This magnet facilitates sensing of the ram position via tie rod mounted sensors.

Characteristics

- Optimally adapted to individual requirements due to its modular design
- Process optimization by means of adjustable parameters (stroke, force, speed)
- Easy adaptation to different tool and part heights because of simplistic stroke and height adjustment
- Additional safety measures when using heavy tools due to the optional device for retention of ram in home position
- End position control via cylinder switches as signal transmitter for peripheral processes
- Low noise level (< 75 dBA)
- Double-acting, wear-resistant cylinders with low air consumption for the return stroke
- High flexibility due to short changeover time
- Long service life and high precision due to wear-resistant Teflon coated bushings at top and bottom of cylinder
- Precision ground ram
- Precision double ram guides

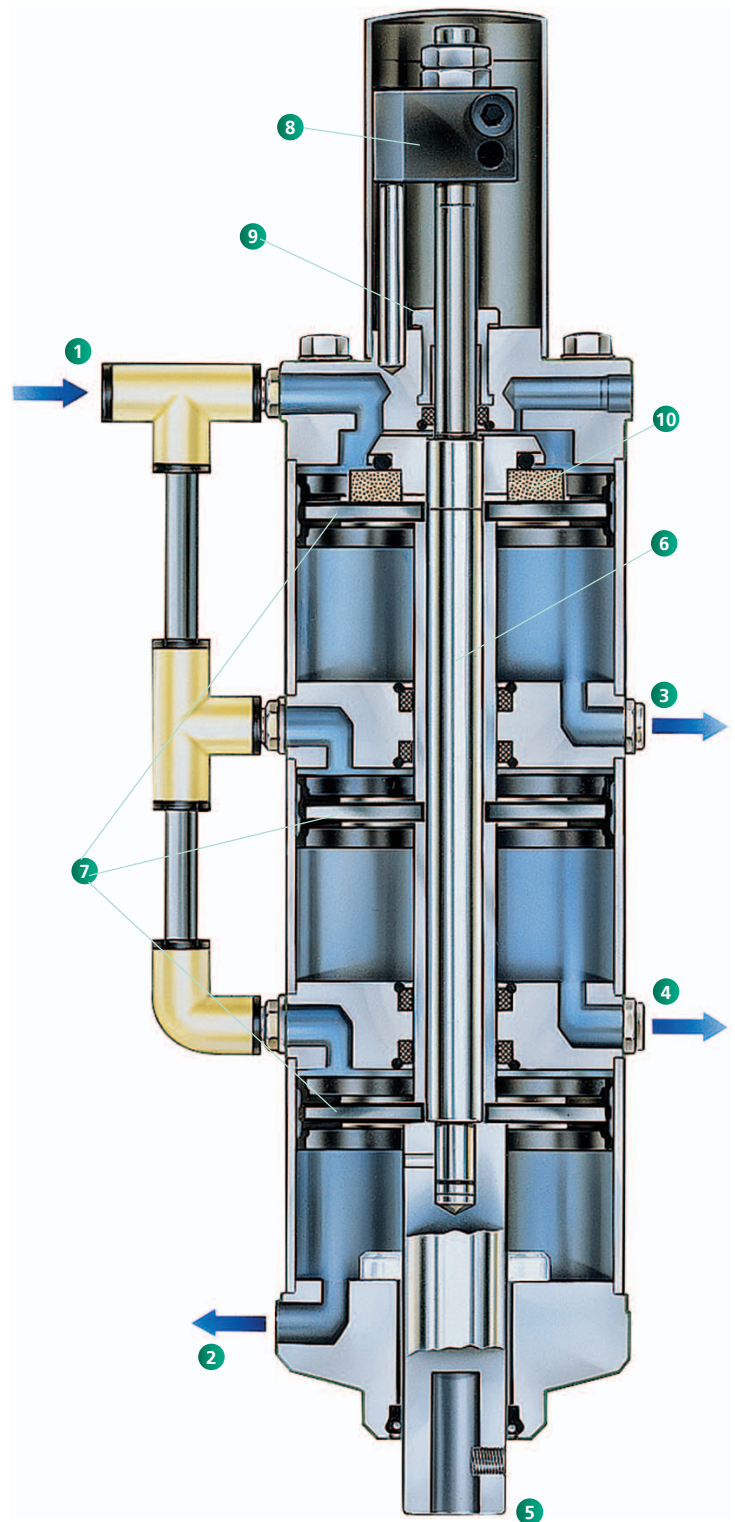

SCHMIDT® PneumaticPress

Direct acting with constant force over the entire stroke

Characteristics

- Round anti-rotational ram
- Adjustable ram position in BDC by means of precision lower stop (1 division line = 0.05 mm) on scale
- T-slot with locking set screw in fixture mounting plate

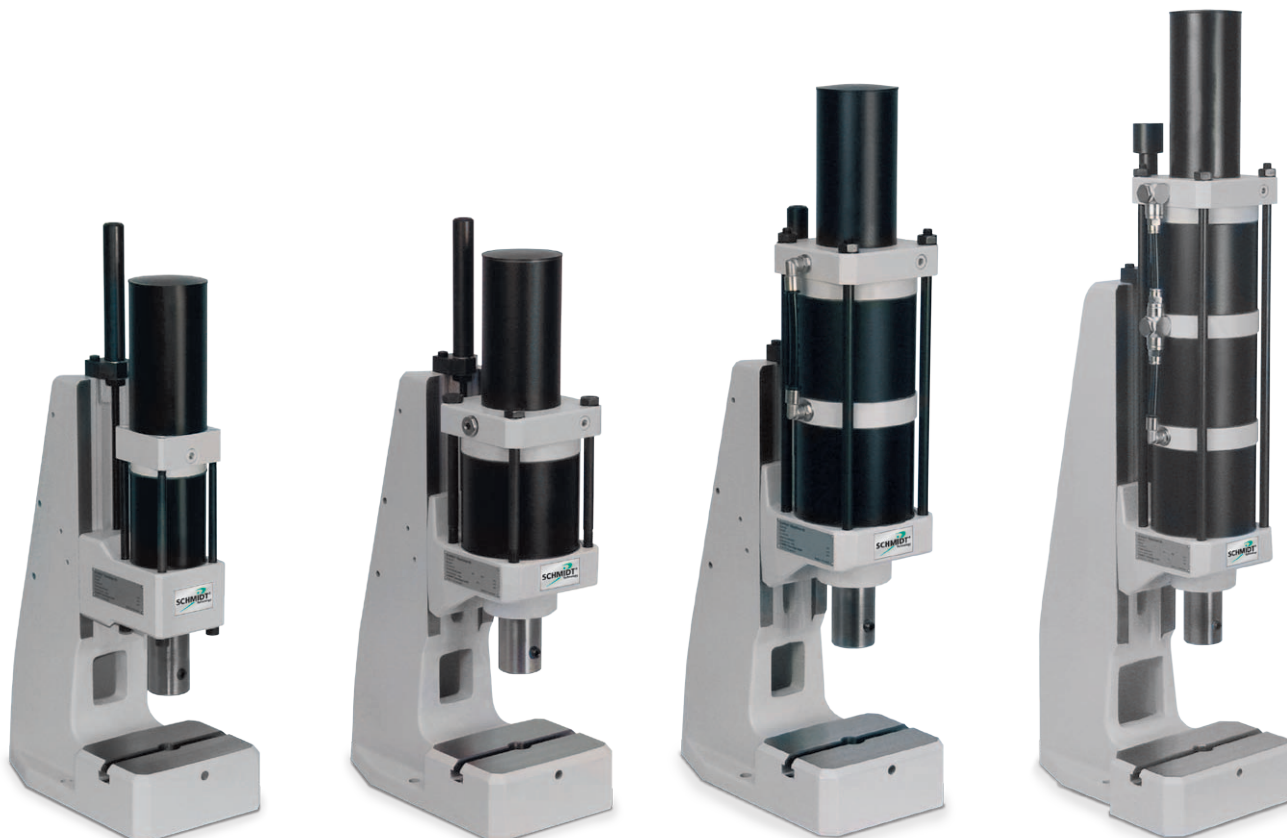

Press Type 20

Press Type 23

Press Type 24

Press Type 25



Pneumatic cylinder with piston and magnet kit for ram position via cylinder switch.

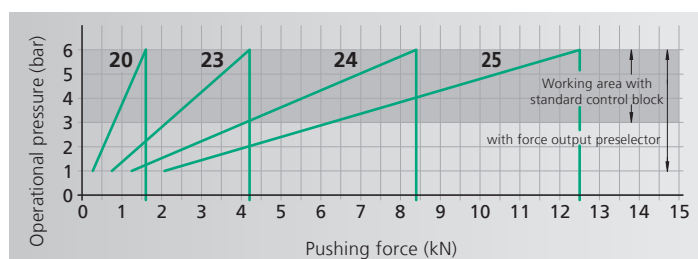

From 1.6 kN to 12.5 kN

Press Type			20	23	24	25
Working stroke up to	A	mm	50, 75 100, 125 160, 200 250, 300	50, 75 100, 125 160, 200 250, 300	50, 75 100, 125 160	50, 75 100
Nominal force at 6 bar		kN	1.6	4.2	8.4	12.5
Throat depth	C	mm	86	86	86	86
Throat depth frame \varnothing		mm	111, 131 160, 200	111, 131 160, 200	111, 131 160, 200	111, 131
Additional fixture mounting plate suitable for throat depth frame			\varnothing	\varnothing	\varnothing	\varnothing
Ram bore	\varnothing	mm	20H7	20H7	20H7	20H7
Ram diameter	\varnothing	mm	40	40	40	40
Working height ¹⁾	F					
Frame No. 3		mm	80-220	90-210	90-210	90-210
Frame No. 2 \varnothing		mm	110-360	120-350	120-350	120-350
Frame No. 2-600 \varnothing		mm	200-600	210-580	210-580	210-580
Frame No. 2-1000 \varnothing		mm	330-1040	335-1020	335-1020	335-1020
Weight		approx. kg	30	35	40	45
Flange model			20-FL	23-FL	24-FL	25-FL
Cylinder	Z	\varnothing mm	69	106	106	106
Flange	FL	\varnothing mm	110	140	140	140
Width across flats	SW	mm	80	112	112	112
Centering shoulder	ZA	\varnothing mm	60	68	68	68

Frame Overview	Press Type	Frame Height M (mm)	Table Size B x T (mm)	Table Bore D \varnothing mm	Table Height K (mm)	Mounting Surface B x L (mm)
No. 3	20, 23, 24, 25	540	150 x 110	20H7	60	150 x 260
No. 2	20, 23, 24, 25	700	185 x 110	20H7	60	185 x 280
No. 2-600 \varnothing	20, 23, 24, 25	974	200 x 160	20H7	98	200 x 290
No. 2-1000 \varnothing	20, 23, 24, 25	1410	200 x 160	20H7	98	200 x 290

Options

\varnothing Additional charge applies

¹⁾ Typical values; can vary ± 3 mm due to casting and production tolerances

Other available options

- Nickel plated – cast parts are electroless nickel plated, steel components black oxide finished, aluminum anodized, precision steel surfaces are untreated
- Custom Paint – press and column can be painted to customer's color specification
- Bores for adapting tooling – customer specific sizes can be supplied

Bottom View of the Press Head, Flange Model

Mounting drill pattern flange/ram

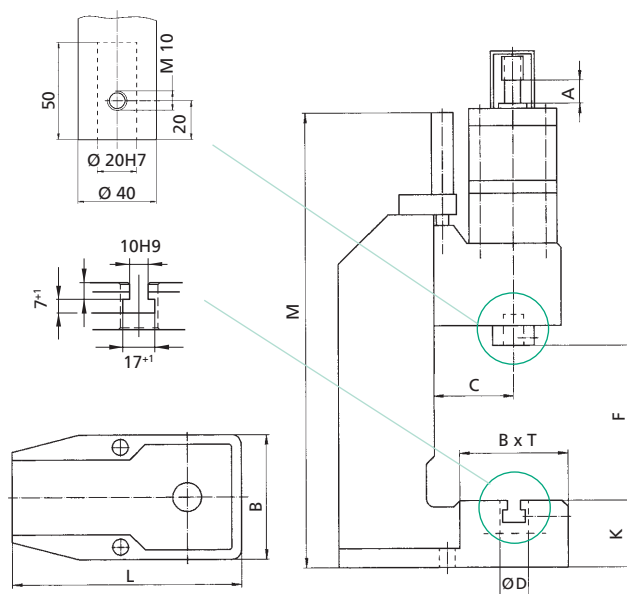
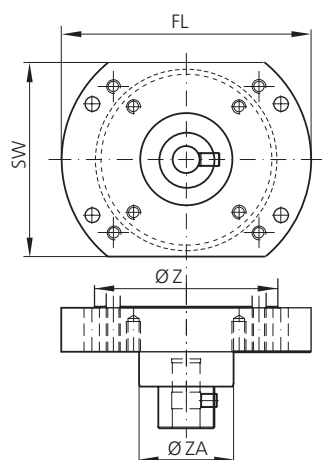

Detailed dimensional drawings can be downloaded: www.schmidttechnology.com

SCHMIDT® PneumaticPress

Direct acting with constant force over the entire stroke

Characteristics

- Round anti-rotational ram
- Adjustable ram position in BDC by means of precision lower stop (1 division line = 0.05 mm) on scale



Press Type 27



Press Type 29



Precision lower stop

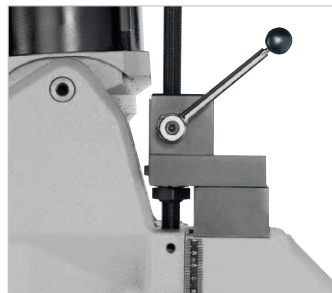

Height adjustment
Fast, accurate setting of the work height.

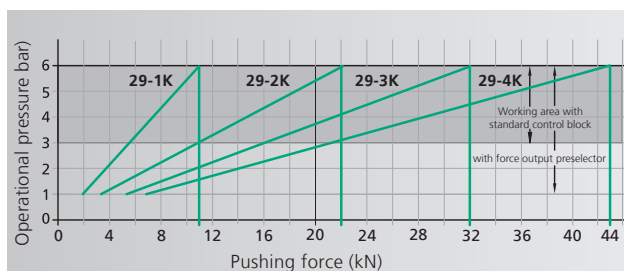
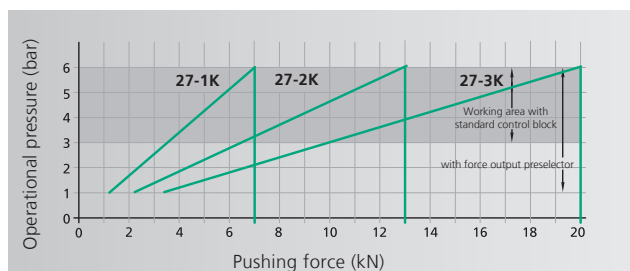

From 7 kN to 43 kN

Press Type			27-1K	27-2K	27-3K	29-1K	29-2K	29-3K	29-4K
Working stroke up to	A	mm	50, 75, 100	50, 75	50, 75	50, 75	50, 75	50, 75	50, 75
			160, 200	100, 125	100, 125	100, 160	100, 125	100, 125	100, 125
			250, 300	160, 200	160	200, 300	160, 200	160	100
Nominal force at 6 bar		kN	7	13	20	11	22	32	43
Throat depth	C	mm	131	131	131	140	140	140	140
Throat depth frame \circ		mm	151	151	151	160, 185	160, 185	160, 185	160
Additional fixture mounting plate suitable for throat depth frame			\circ	\circ	\circ	\circ	\circ	\circ	\circ
Ram bore	\emptyset	mm	20H7	20H7	20H7	20H7	20H7	20H7	20H7
Ram diameter	\emptyset	mm	40	40	40	50	50	50	50
Working height ¹⁾									
Frame No. 34		mm	90-270	90-270	90-270				
Frame No. 301 \circ		mm	160-400	160-400	160-400				
Frame No. 301-500 \circ		mm	310-550	310-550	310-550				
Frame No. 29		mm				80-290	80-290	80-290	80-290
Frame No. 29-500 \circ		mm				150-500	150-500	150-500	150-500
Frame No. 29-600 \circ		mm				250-600	250-600	250-600	250-600
Weight (standard)		approx. kg	85	85	85	120	120	120	120
Flange model			27-1K-FL	27-2K-FL	27-3K-FL	29-1K-FL	29-2K-FL	29-3K-FL	29-4K-FL
Cylinder	Z	\emptyset mm	132	132	132	170	170	170	170
Flange	FL	\emptyset mm	180	180	180	220	220	220	220
Width across flats	SW	mm	140	140	140	180	180	180	180
Centering shoulder	ZA	\emptyset mm	68	68	68	80	80	80	80

Frame Overview	Press Type	Frame Height M (mm)	Table Size B x T (mm)	Table Bore D \emptyset mm	Table Height K (mm)	Mounting Surface B x L (mm)
No. 34	27	630	200 x 160	25H7	111	200 x 370
No. 301	27	830	250 x 200	40H7	145	250 x 460
Frame No. 301-500 \circ	27	990	250 x 200	40H7	145	250 x 480
Special fixture mounting plate with 3 longitudinal slots \circ			300 x 220 400 x 230	40H7 40H7		
Frame No. 29	29	690	300 x 220	40H7	141	300 x 460
Frame No. 29-500 \circ	29	990	300 x 220	40H7	166	300 x 540
Frame No. 29-600 \circ	29	1110	300 x 220	40H7	166	300 x 565
Special fixture mounting plate with 3 longitudinal slots \circ			355 x 225 400 x 230	40H7 40H7		

¹⁾ Typical values; can vary ± 3 mm due to casting and production tolerances

Options

\circ Additional charge applies

Other available options

- Nickel plated – cast parts are electroless nickel plated, steel components black oxide finished, aluminum anodized, precision steel surfaces are untreated
- Custom Paint – press and column can be painted to customer's color specification
- Bores for adapting tooling – customer specific sizes can be supplied

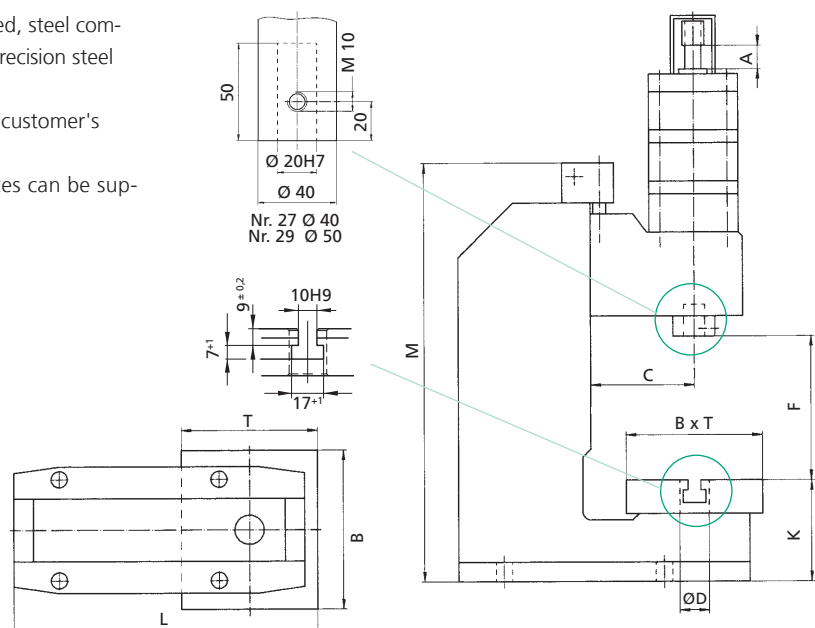
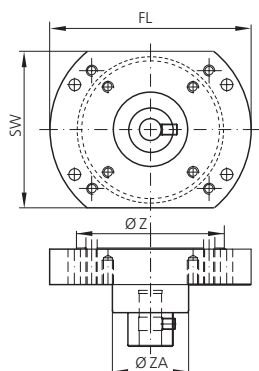

Detailed dimensional drawings can be downloaded: www.schmidttechnology.com

SCHMIDT® PneumaticPress

Pneumatic Toggle Presses with maximum force at the end of stroke

Characteristics

- Cross hole with locking screw in the press table for safe fixture of tool
- Accurate adjustable ram position via fine adjustment (type 33)
- T-slot with set screw in fixture mounting plate to secure bottom tool

Press Type 32

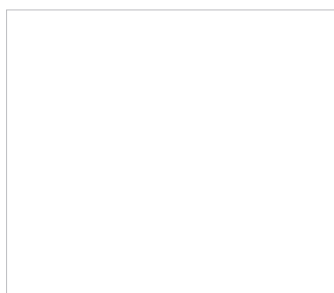

Press Type 33

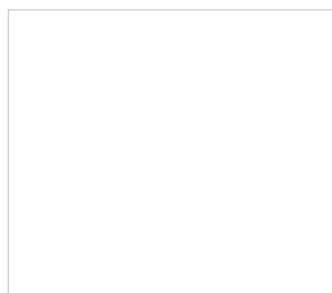

Fine adjustment
for press No. 33 with scale
1 division line = 0.02 mm.

Flexible stroke adjustment
reduces the air consumption
for shorter strokes.

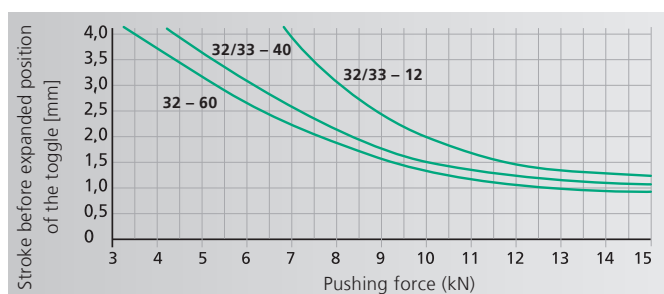

Up to 15 kN

Press Type			32	33
Working stroke up to	A	mm	0-12 4-40 6-60	0-12 4-40
Nominal force at 6 bar		kN	15	15
Throat depth	C	mm	86	86
Throat depth frame \varnothing		mm	111, 131	111, 131
Additional fixture mounting plate suitable for throat depth frame			\varnothing	\varnothing
Ram bore	\varnothing	mm	20H7	20H7
External ram dimensions	\varnothing	mm	40	40
Fine adjustment				●
Working height ¹⁾	F			
Frame No. 3 \varnothing		mm	80 – 205	
Frame No. 5		mm	80 – 350	35 – 295
Frame No. 2-600 \varnothing		mm	200 – 575	155 – 520
Frame No. 2-1000 \varnothing		mm	330 – 1020	285 – 965
Weight		approx. kg	45	50

Frame Overview	Press Type	Frame Height M (mm)	Table Size B x T (mm)	Table Bore D \varnothing (mm)	Table Height K (mm)	Mounting Surface B x L (mm)
No. 3	32	540	150 x 110	20H7	60	150 x 260
No. 5	32, 33	536	185 x 110	20H7	60	185 x 280
Frame No. 2-600 \varnothing	32, 33	810	200 x 160	20H7	98	200 x 290
Frame No. 2-1000 \varnothing	32, 33	1248	200 x 160	20H7	98	200 x 290

Options

- Series standard with no additional charge
- Additional charge may apply
- ¹⁾ Typical values; can vary ± 3 mm due to casting and production tolerances

Other available options

- Nickel plated – cast parts are electroless nickel plated, steel components black oxide finished, aluminum anodized, precision steel surfaces are untreated
- Custom Paint – press and column can be painted to customer's color specification
- Bores for adapting tooling – customer specific sizes can be supplied

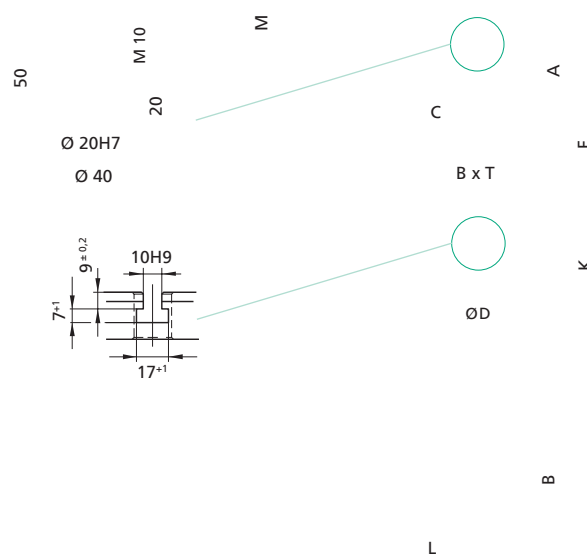

Detailed dimensional drawings can be downloaded: www.schmidttechnology.com

SCHMIDT® PneumaticPress

Pneumatic Toggle Presses with maximum force at the end of stroke

Characteristics

- Anti-rotational square ram with fully adjustable, Teflon lined gibs for precise travel, no die set required
- Exact positioning due to fine adjustment scale (1 division line = 0.05 mm)

Press Type 34

Press Type 36

Square ram

Fine adjustment

Pushing Force Diagram

Operational pressure: 6 bar

Stroke before expanded position
of the toggle [mm]

Pushing force (kN)

From 28 kN to 60 kN

Press Type			34	36
Working stroke up to	A	mm	0-12 4-40 6-60	0-12 4-40 6-60
Nominal force at 6 bar		kN	28	60
Throat depth	C	mm	131	160
Throat depth frame ϕ		mm	151	185
Fixture mounting plate suitable for throat depth frame			ϕ	ϕ
Ram bore	ϕ	mm	20H7	20H7
External ram dimensions	G x H	mm	36 x 63	46 x 86
Working height ¹⁾	F			
Frame No. 34		mm	100-250	
Frame No. 301		mm	160-400	
Frame No. 301-500		mm	310-550	
Frame No. 35		mm		100 - 250
Frame No. 35-500		mm		150-500
Frame No. 35-600		mm		250-600
Weight		approx. kg	90	150

Frame Overview	Press Type	Frame Height M (mm)	Table Size B x T (mm)	Table Bore D ϕ mm	Table Height K (mm)	Mounting Surface B x L (mm)
No. 34	34	630	200 x 160	25H7	111	200 x 370
No. 301	34	830	250 x 200	40H7	145	250 x 460
No. 301-500	34	990	250 x 200	40H7	145	250 x 480
Special fixture mounting plate with 3 longitudinal slots ϕ			300 x 220 400 x 230	40H7		
No. 35	36	700	300 x 220	40H7	141	300 x 480
No. 35-500	36	990	300 x 220	40H7	166	300 x 560
No. 35-600	36	1110	300 x 220	40H7	166	300 x 585
Special fixture mounting plate with 3 longitudinal slots ϕ			355 x 225 400 x 280	40H7		

Options

ϕ Additional charge applies

¹⁾ Typical values; can vary ± 3 mm due to casting and production tolerances

Other available options

- Nickel plated – cast parts are electroless nickel plated, steel components black oxide finished, aluminium anodized, precision steel surfaces are untreated
- Custom Paint – press and column can be painted to customer's color specification
- Bores for adapting tooling – customer specific sizes can be supplied

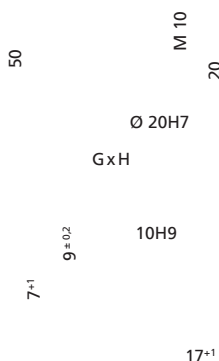

Detailed dimensional drawings can be downloaded: www.schmidttechnology.com

SCHMIDT® PneumaticPress

Direct acting Pneumatic Presses with force/stroke monitoring

SCHMIDT® PneumaticPresses with force/stroke monitoring are offered as complete systems with the SCHMIDT® PressControl 700 and 7000. These systems are characterized by sensors and signal amplification integrated in the press head. These signals are evaluated in real time.

Characteristics

- Direct forces are measured due to the force sensor integrated in the ram. Insensitive against side loads
- Force and displacement sensors are immune to EMI and environmental contamination
- A measuring data amplification integrated in the press head provides short transmission paths of unamplified signals
- Anti-rotational square ram with two fully adjustable guiding gibs for precise work and for non-guided tools
- Weld constructed steel frames to minimize frame flex.



Press Type 327, 329

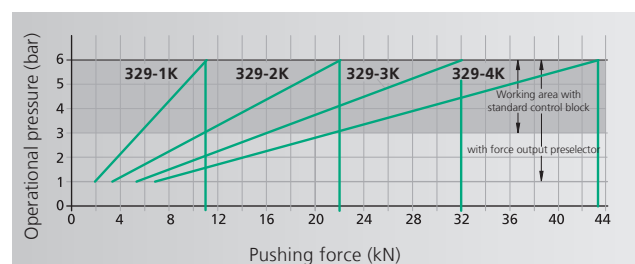

From 1.6 kN to 43 kN

Press Type			327-3K	329-2K	329-3K	329-4K
Working stroke up to	A	mm	50, 75, 100	50, 75, 100, 150	50, 75, 100, 125, 150	50, 75, 100
Nominal force at 6 bar		kN	20	22	32	43
Resolution, process data acquisition						
- stroke		µm/inc	5	5	5	5
- force		N/inc	6.25	6.25	10	12.5
Throat depth	C	mm	131	160	160	160
Throat depth frame \varnothing		mm	151			
Fixture mounting plate suitable for throat depth frame			\varnothing			
Ram bore	\varnothing	mm	20H7	20H7	20H7	20H7
External ram dimensions	G x H	mm	70 x 50	90 x 60	90 x 60	90 x 60
Working height ¹⁾	F					
Frame No. 7-420		mm				
Frame No. 7-600 \varnothing		mm				
Frame No. 301		mm	140 – 350			
Frame No. 301-500 \varnothing		mm	310 – 500			
Frame No. 329		mm		130 – 300	130 – 300	130 – 300
Frame No. 329-460 \varnothing		mm		190 – 460	190 – 460	190 – 460
Weight (standard)		approx. kg	170	320	325	330

Frame Overview	Press Type	Frame Height M (mm)	Table Size B x T (mm)	Table Bore D \varnothing mm	Table Height K (mm)	Mounting Surface B x L (mm)
No. 301	327	830	250 x 200	40H7	145	250 x 460
No. 301-500	327	990	250 x 200	40H7	145	250 x 480
Special fixture mounting plate with 3 longitudinal slots ²⁾ \varnothing			300 x 220 400 x 230	40H7		
No. 329	329	810	300 x 230	40H7	147	300 x 550
No. 329-460	329	990	300 x 230	40H7	147	300 x 620
Special fixture mounting plate with 3 longitudinal slots ²⁾ \varnothing			400 x 280 500 x 280	40H7		

Options

\varnothing Additional charge applies

¹⁾ Typical values; can vary ± 3 mm due to casting and production tolerances

Other available options

- Nickel plated – cast parts are electroless nickel plated, steel components black oxide finished, aluminium anodized, precision steel surfaces are untreated
- Custom Paint – press and column can be painted to customer's color specification
- Bores for adapting tooling – customer specific sizes can be supplied

Bottom view of the press head

Fastening drill pattern flange/ram

Press Type 327

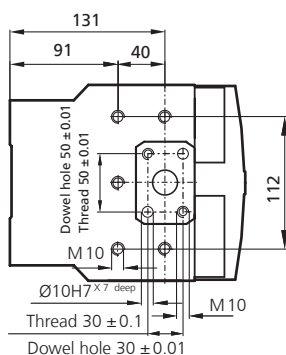

Press Type 329

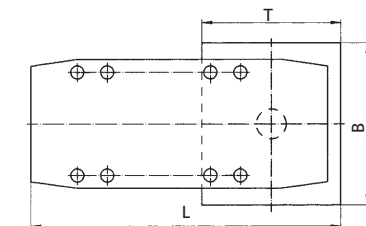
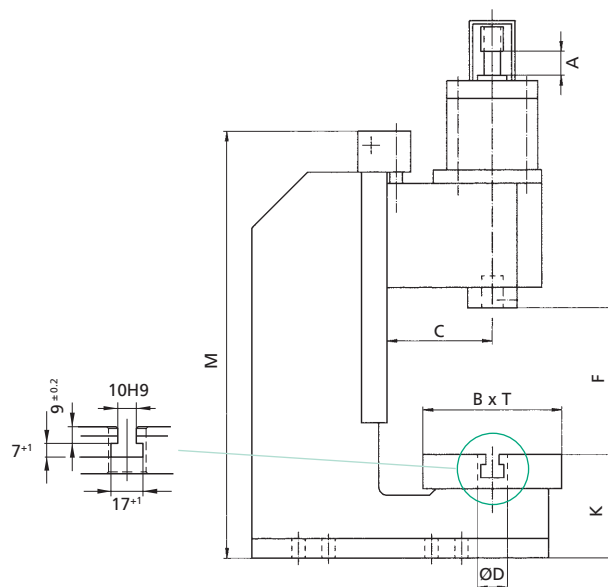
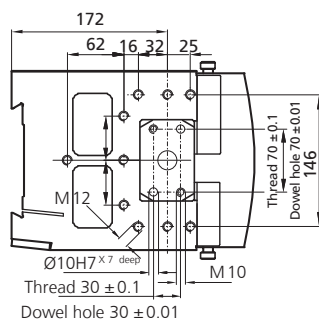

Detailed dimensional drawings can be downloaded: www.schmidttechnology.com



SCHMIDT® PneumaticPress with PressControl 700 and two-hand release on height-adjustable PU40 and transparent guarding as EC type-examination approved single workstation.

SCHMIDT® HydroPneumaticPress

Maximum force range from 15 kN to 220 kN

The **SCHMIDT® HydroPneumaticPress** range builds on a modular concept and can generate up to 220 kN. They are ideally suited for joining, assembly and forming applications. With the addition of the **SCHMIDT® PressControl 75** or **700** and the optional process monitoring, these presses become EC type-approved, CE-conformed workstations. Therefore these press systems can be used in either single cycle or automatic mode.

The application determines selection of the press system. Consideration is given to the flexible design of the assembly location taking into account the ergonomic and safety aspects. These characteristics are achieved by means of a finely adjusted, modular type product range. The efficiency and increased process reliability of these press systems have been proven many times, in single applications, semi-automated assembly systems and have been integrated into automated production lines.



SCHMIDT® HydroPneumaticPress

System design



- 1 Cylinder unit**
Hydro pneumatic
- 2 Flow control rapid approach stroke**
For speed control of the downstroke
- 3 Press head unit**
Modular design allows for quick and accurate height adjustment when installed on our column or the system can be easily integrated, in any orientation, to an automated press solution.
- 4 Pneumatic control package**
Two-channel pneumatic package (as shown) is based on a modular valve block
- 5 Force output preselector**
The press force output can easily be controlled via a separate pressure regulator and pressure gauge. The pressure for the power stroke can be reduced to 1 bar
- 6 Square ram**
Square ram with precision machine bore and fully adjustable Teflon line gibs for precise ram guidance.
- 7 Frame**
With precision machined press head guide rails (for No. 68 and 368 designed as dovetail guide)
- 8 Fixture mounting plate**
With precision T-slot and precision bore for tool location



Stroke feedback

Ram with key-ways for switch target pieces for an inductive position feedback. Optional: Stroke-dependent activation of the power stroke by means of the proximity switch.

SCHMIDT® HydroPneumaticPress

Principle of operation

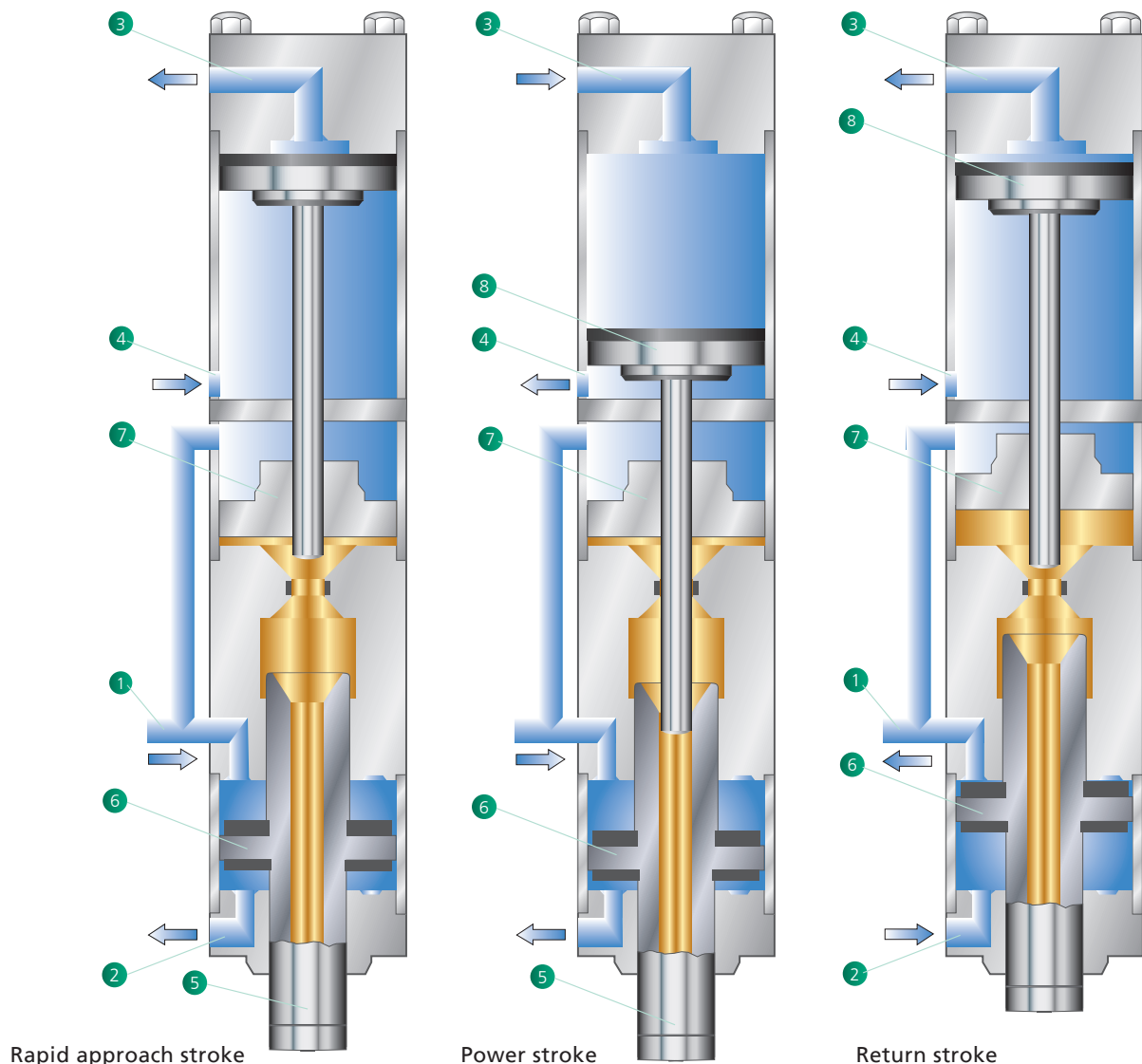

Rapid approach stroke

In rapid approach stroke, the air connections 1 and 4 are pressurized with compressed air. The air connections 2 and 3 are depressurized. The approach stroke piston 6 and the reservoir piston 7 are moving with low force until the ram 5 encounters resistance.

Power Stroke

If the ram 5 encounters resistance, a valve switches the compressed air from 4 to connection 3, and the power stroke piston 8 moves downwards. A rod enters the high pressure cylinder, separating the hydraulic oil between reservoir piston 7 and approach stroke piston 6. The ram 5 moves out with boosted force.

Return Stroke

For the return stroke, the connections 1 and 3 are depressurized, and the connections 2 and 4 are pressurized. Approach stroke 6 and power stroke piston 8 move back simultaneously. After the hydraulic connection between approach 6 and reservoir piston 7 oil flows back into the reservoir, moving the reservoir piston into its home position.

Characteristics

- Optimally adapted to individual requirements due to its modular design
- High flexibility and economic efficiency due to short changeover times
- Easy and accurate positioning of tools due to the precise alignment between ram bore and the ground fixture mounting plate.
- The force output preselector allows reducing the pressure for the power stroke to 1 bar. This reduces the nominal press force to 1/6 of the maximum force.
- The end positions of the ram can be sensed via the inductive proximity switches.
- No mechanical compression spring in the cylinder of the hydro-pneumatic system, providing a long service life
- Low maintenance resulting in high productivity
- Long service life and precision due to maintenance-free guides
- Tool protection due to smooth switchover from rapid approach stroke to power stroke
- Additional safety when using heavy tools due to the optional ram drift lock device for retention of ram in home position.
- Low noise level (< 75 dBA)

SCHMIDT® HydroPneumaticPress

C-Frame design

Characteristics

- The C-Frame design offers full accessibility when manually inserting and removing parts
- Easy adaptation to different tool and part heights because of simplistic height adjustment with angular gear
- Anti-rotational square ram with fully adjustable, Teflon lined gibs for precise travel. No die set required
- High precision due to long precise guides of the square ram

Press type 61/62

Press type 65

Adjustable switch target pieces for position detection via an inductive position sensor

Rapid approach stroke

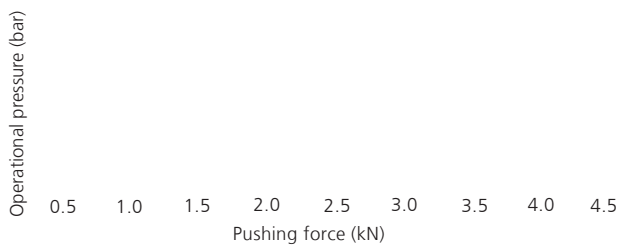

Square ram
with bilaterally adjustable, play-free gibs, precision machined bore with set screw for mounting of tooling.

Power stroke

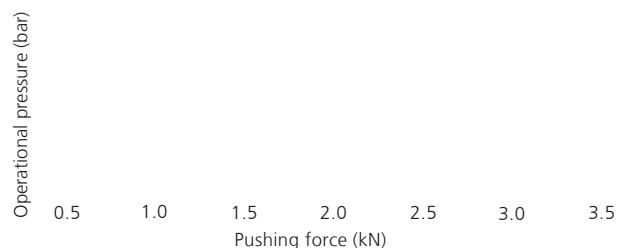
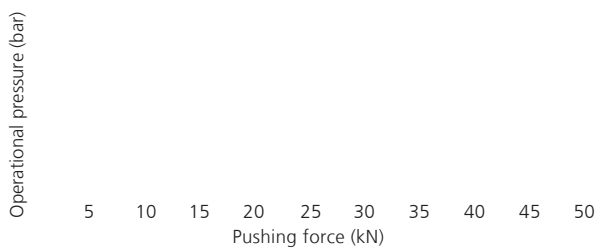

Operational pressure < 3 bar: can only be operated with press force preselector!

From 15 kN to 52 kN in power stroke

Press Type			61	62	65
Total stroke – power stroke ¹⁾		mm	50 – 6, 100 – 12	50 – 6, 100 – 12	50 – 6, 100 – 12
Nominal force at 6 bar		kN	15	30	52
Throat depth	C	mm	131	131	160
Throat depth frame o		mm	151	151	185
Fixture mounting plate suitable for throat depth frame			o	o	o
Ram bore	Ø	mm	20H7	20H7	20H7
External ram dimensions	G x H	mm	36 x 63	36 x 63	46 x 86
Working height ²⁾	F				
Frame No. 34		mm	100 – 250	100 – 250	
Frame No. 301 o		mm	160 – 400	160 – 400	
Frame No. 301-500 o		mm	310 – 550	310 – 550	
Frame No. 35		mm			80 – 270
Frame No. 35-500 o		mm			150 – 500
Frame No. 35-600 o		mm			250 – 600
Weight (standard)	approx. kg		95	110	160

Frame Overview	Press Type	Frame Height M (mm)	Table Size B x T (mm)	Table Bore D Ø mm	Table Height K (mm)	Mounting Surface B x L (mm)
No. 34	61, 62	630	200 x 160	25H7	111	200 x 370
No. 301	61, 62	830	250 x 200	40H7	145	250 x 460
No. 301-500	61, 62	990	250 x 200	40H7	145	250 x 480
Special fixture mounting plate with 3 longitudinal slots o			300 x 220 400 x 230	40H7		
No. 35	65	700	300 x 220	40H7	141	300 x 480
No. 35-500	65	990	300 x 220	40H7	166	300 x 560
No. 35-600	65	1110	300 x 220	40H7	166	300 x 585
Special fixture mounting plate with 3 longitudinal slots o			355 x 225 400 x 280	40H7		

Options

o Additional charge applies

¹⁾ Total stroke / power stroke options on request

²⁾ Typical values; can vary ± 3 mm due to casting and production tolerances

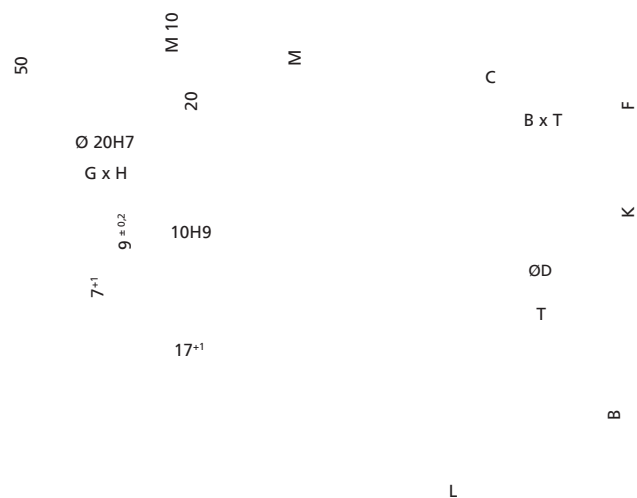

Detailed dimensional drawings can be downloaded: www.schmidttechnology.com

SCHMIDT® HydroPneumaticPress

C-Frame design with welded press frame

Characteristics

- The welded press frame offers highest stability
- Space-saving and compact due to separate working cylinder for press No. 68



Press type 68



Press type 64



Square ram

with bilaterally adjustable, play-free gibs, precision machined bore with set screw for mounting of tooling. Some models feature additional provisions for tooling adaption.

Rapid approach stroke

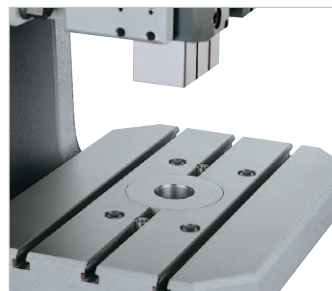
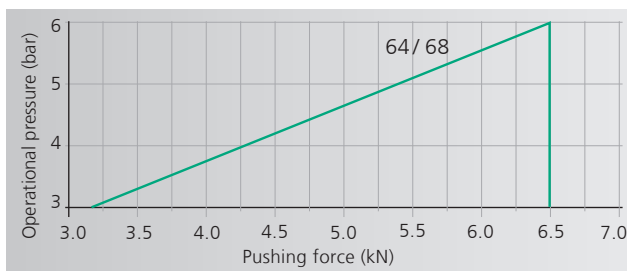

Fixture mounting plate

(for Press No. 64) with 3 T-slots and precision machined bore for tool location.

Power stroke

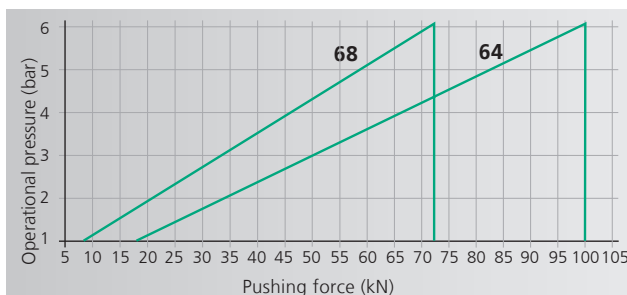

Return stroke

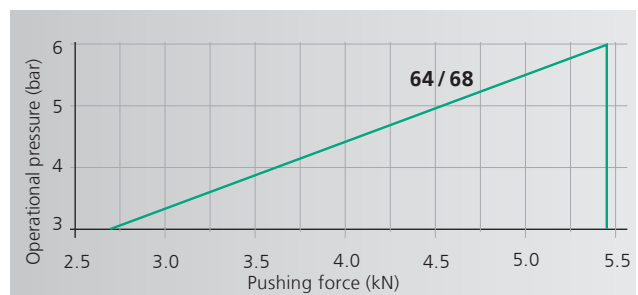

Operational pressure < 3 bar: can only be operated with press force preselector!

From 72 kN to 100 kN in power stroke

Press Type			64	68
Total stroke - Power stroke ¹⁾		mm	50-6, 100-12	50-6, 100-12
Nominal force at 6 bar		kN	100	72
Throat depth	C	mm	160	160
Ram bore	E	Ø mm	25H7	20H7
External ram dimensions	G x H	mm	60 x 90	60 x 90
Working height ²⁾	F			
Frame No. 64		mm	180-350	
Frame No. 64-600 o		mm	430-600	
Frame No. 68 ²⁾		mm		130-300
Frame No. 68/5 ²⁾ o		mm		190-460
Weight (standard)		approx. kg	420	350

Frame Overview	Press Type	Frame Height M (mm)	Table Size B x T (mm)	Table Bore D Ø mm	Table Height K (mm)	Mounting Surface B x L (mm)
No. 64	64	940	400 x 290	40H7	185	400 x 625
No. 64-600 o	64	1200	400 x 290	40H7	185	400 x 685
No. 68 ²⁾	68	810	300 x 230	40H7	147	300 x 550
No. 68/5 ²⁾ o	68	990	300 x 230	40H7	147	300 x 620
Special fixture mounting plate with 3 longitudinal slots o			400 x 280 500 x 280	40H7		

Options

o Additional charge applies

¹⁾ Total stroke / power stroke options on request

²⁾ Frame 68/5 required for 30 mm power stroke

³⁾ Typical values; can vary ±3 mm due to casting and production tolerances

Bottom view of the press head

Mounting drill pattern flange/ram

Press type 64

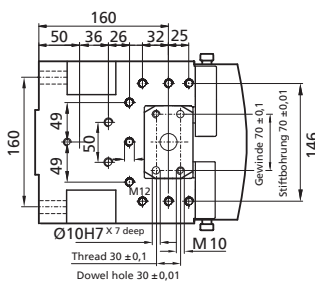

Press type 68

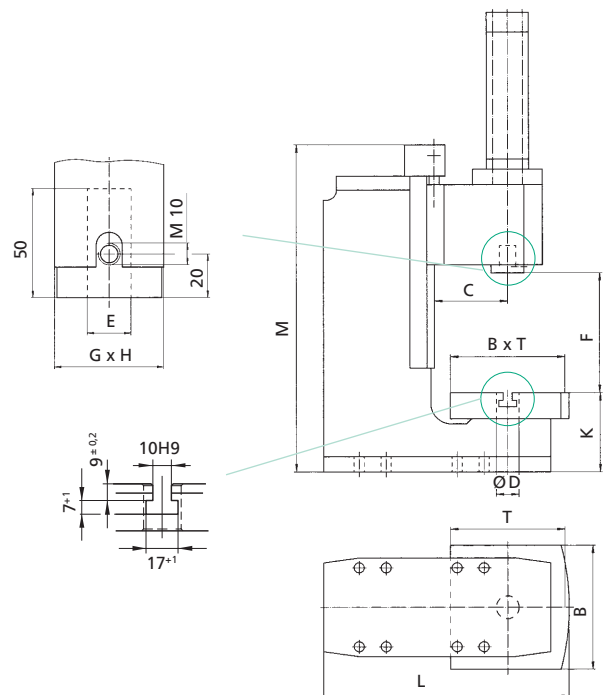
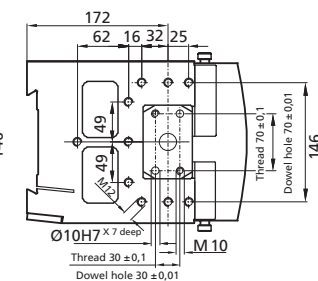

Detailed dimensional drawings can be downloaded: www.schmidttechnology.com

SCHMIDT® HydroPneumaticPress

C-Frame design with force/stroke monitoring

SCHMIDT® HydroPneumaticPresses with force / stroke monitoring are offered as complete systems with control unit SCHMIDT® PressControl 700 and 7000. These systems are characterized by sensors and signal amplification integrated in the press head. These signals are evaluated in real time.

Characteristics

- Direct forces are measured due to the force sensor integrated in the ram. Insensitive against side forces
- Signal readings are not affected by outside interference
- A measuring data amplification integrated in the press head provides short transmission paths of unamplified signals
- Precision guide rails for precise working. Bilaterally adjustable, play-free gibs, precision machined bore for tool location. No die-set required
- Weld constructed steel frames to minimize frame flex.



Press type 361



Press type 362



Press type 365

Rapid approach stroke

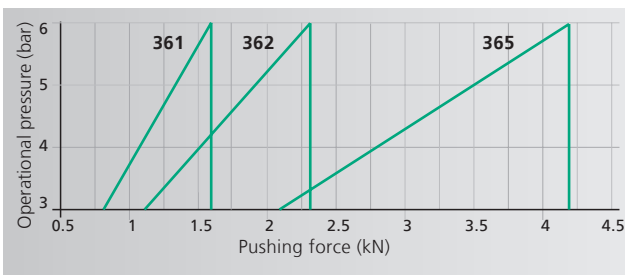

Power stroke

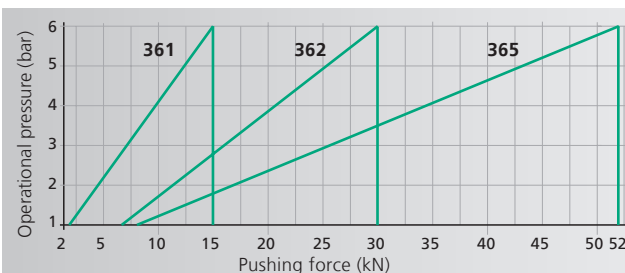

Return stroke

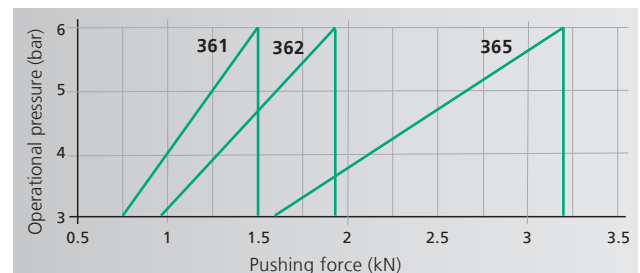

Operational pressure < 3 bar: can only be operated with press force preselector!

From 15 kN to 52 kN in power stroke

Press Type		361	362	365
Total stroke - Power stroke ¹⁾	mm	50-6, 100-12	50-6, 100-12	50-6, 100-12
Nominal force at 6 bar	kN	15	30	52
Process data acquisition stroke force	µm/inc	5	5	5
	N/inc	4.5	9	15
Throat depth	C mm	131	160	160
Throat depth frame \varnothing		151		
Fixture mounting plate suitable for throat depth frame		\varnothing		
Ram bore	\varnothing mm	20H7	20H7	20H7
External ram dimensions	G x H mm	70 x 50	90 x 60	90 x 60
Working height ²⁾	F			
Frame No. 301	mm	160-355		
Frame No. 301-500 \varnothing	mm	310-500		
Frame No. 329	mm		130-300	130-300
Frame No. 329-460 \varnothing	mm		190-460	190-460
Weight (standard)	approx. kg	170	320	330

Frame Overview	Press Type	Frame Height M (mm)	Table Size B x T (mm)	Table Bore D \varnothing mm	Table Height K (mm)	Mounting Surface B x L (mm)
No. 301	361	830	250 x 200	40H7	145	250 x 460
No. 301-500 \varnothing	361	990	250 x 200	40H7	145	250 x 480
Special fixture mounting plate with 3 longitudinal slots \varnothing			300 x 220 400 x 230	40H7		
No. 329	362, 365	810	300 x 230	40H7	147	300 x 550
No. 329-460 \varnothing	362, 365	990	300 x 230	40H7	147	300 x 620
Special fixture mounting plate with 3 longitudinal slots \varnothing			400 x 280 500 x 280	40H7		

Options

\varnothing Additional charge applies

¹⁾ Total stroke / power stroke options on request

²⁾ Typical values; can vary ± 3 mm due to casting and production tolerances

Bottom view of the press head

Mounting drill pattern flange/ram

Press Type 361

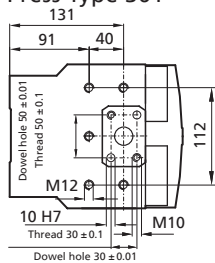

Press Type 362/365

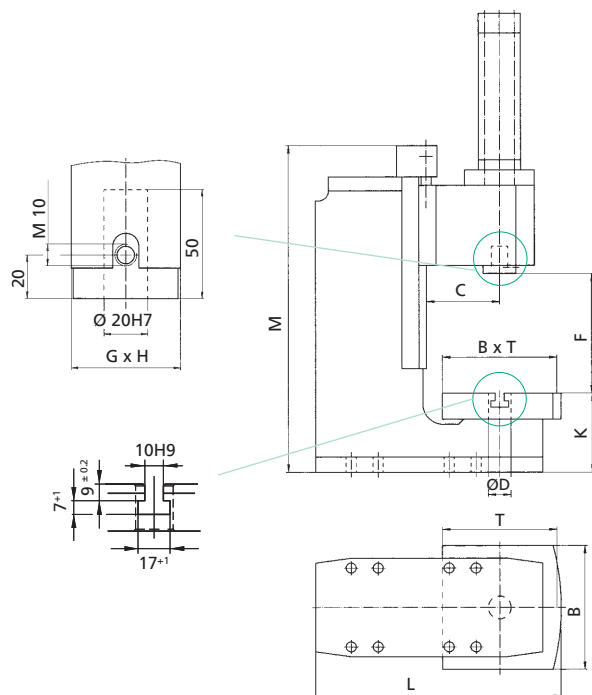
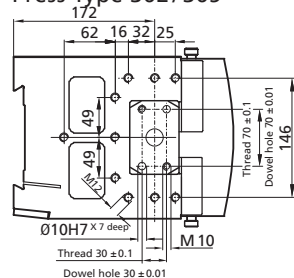

Detailed dimensional drawings can be downloaded: www.schmidttechnology.com

SCHMIDT® HydroPneumaticPress

In C-Frame design with force/stroke Monitoring

SCHMIDT® HydroPneumaticPress with force/stroke monitoring are offered as complete systems with control unit SCHMIDT® PressControl 700 and 7000. These systems are characterized by sensors and signal amplification integrated in the press head. These signals are evaluated in real time.

Characteristics

- Direct forces are measured due to the force sensor integrated in the ram. Insensitive against side forces
- Signal readings are not affected by outside interference
- A measuring data amplification integrated in the press head provides short transmission paths of unamplified signals
- Precision bilaterally adjustable, play-free gibs, precision ground bore for tool location. No die-set required
- Weld constructed steel frames to minimize frame flex.



Press type 364



Press type 368

Rapid approach stroke

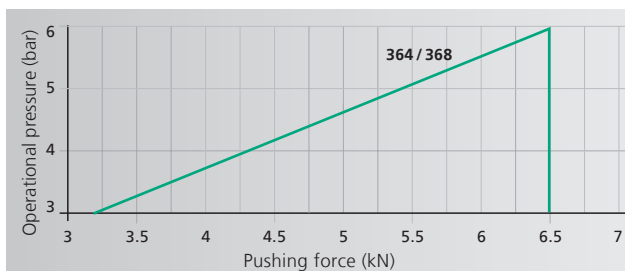

Power stroke

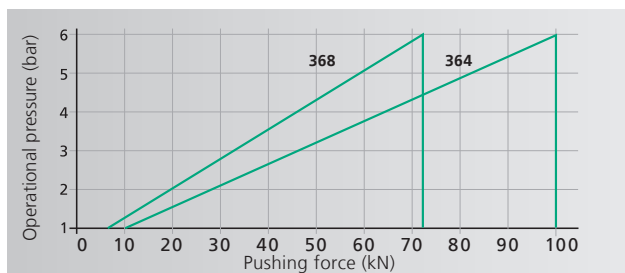

Return stroke

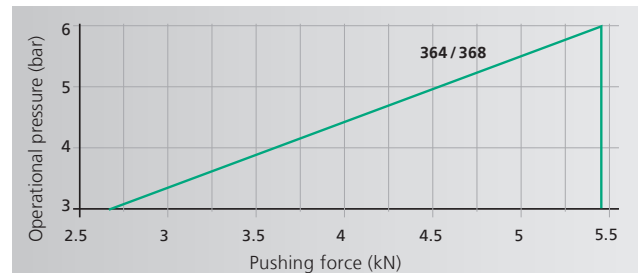

From 72 kN to 100 kN in power stroke

Press Type			364	368
Total stroke - Power stroke ¹⁾		mm	50-6, 100-12	50-6, 100-12
Nominal force at 6 bar		kN	100	72
Process data acquisition				
Stroke		µm/inc	5	5
Force		N/inc	32	20
Throat depth	C	mm	160	160
Ram bore	E	Ø mm	25H7	20H7
External ram dimensions	G x H	Ø mm	90 x 60	90 x 60
Working height ³⁾	F			
Frame No. 64		mm	180-350	
Frame No. 64-600 o		mm	430-600	
Frame No. 68 ²⁾		mm		130-300
Frame No. 68/5 ²⁾ o		mm		190-460
Weight (standard)		approx. kg	420	350

Frame Overview	Press Type	Frame Height M (mm)	Table Size B x T (mm)	Table Bore D Ø mm	Table Height K (mm)	Mounting Surface B x L (mm)
No. 64	364	940	400 x 290	40H7	185	400 x 625
No. 64-600 o	364	1200	400 x 290	40H7	185	400 x 685
No. 68 ²⁾	368	810	300 x 230	40H7	147	300 x 550
No. 68/5 ²⁾ o	368	990	300 x 230	40H7	147	300 x 620
Special fixture mounting plate with 3 longitudinal slots o			400 x 280 500 x 280	40H7		

Options

o Additional charge applies

¹⁾ Total stroke / power stroke options on request

²⁾ Frame 68/5 required for 30 mm power stroke

³⁾ Typical values; can vary ±3 mm due to casting and production tolerances

Bottom View of the Press Head Mounting drill pattern flange/ram

Press Type 364

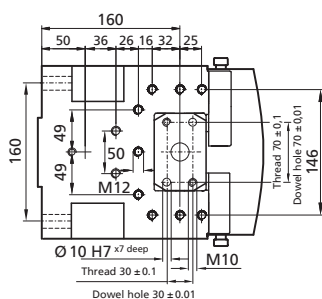

Press Type 368

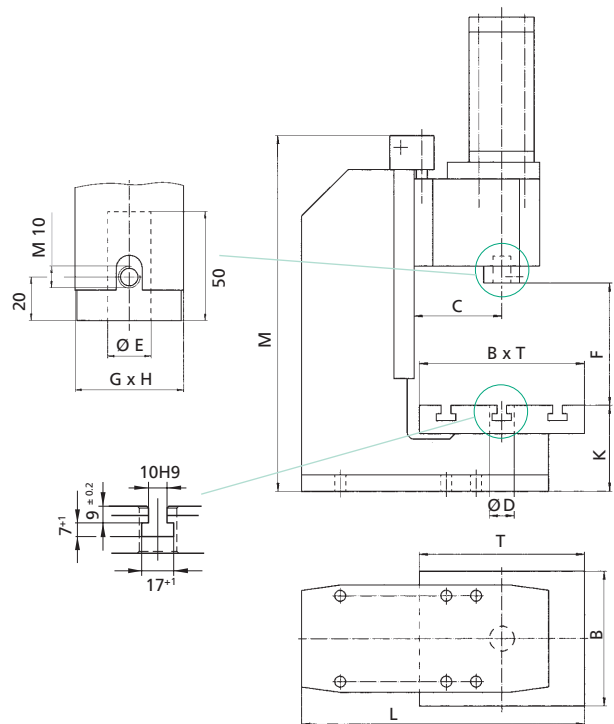
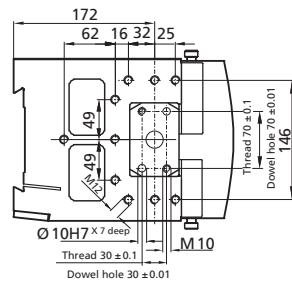

Detailed dimensional drawings can be downloaded: www.schmidttechnology.com

SCHMIDT® HydroPneumaticPress

H-Frame design with and without force/stroke monitoring

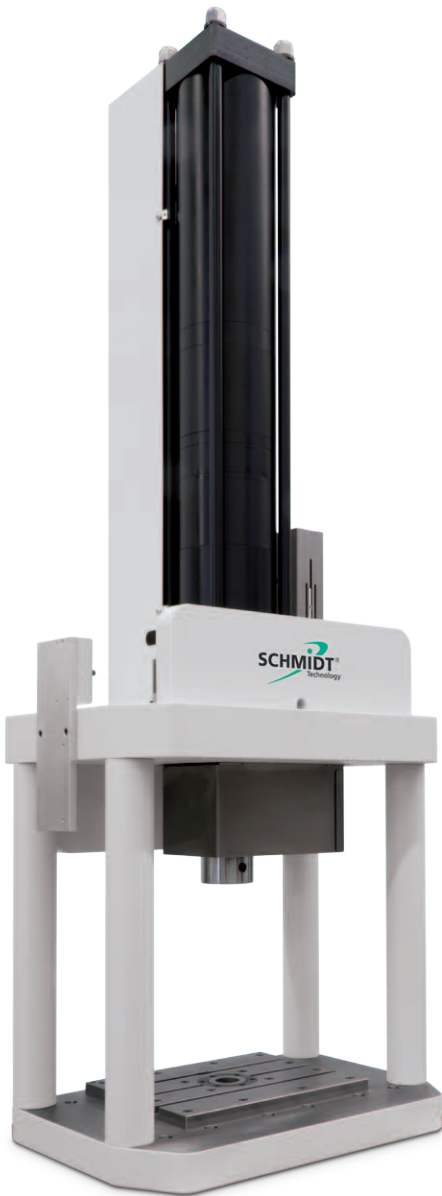

Press type 74/76
374/376 (with force/stroke monitoring)

Characteristics

- Stable frame with low bending for the absorption of high forces
- Flexible tool location in the fixture mounting plate due to replaceable centering bushing with precision bore
- The large working area offers sufficient space for large tools
- The force is determined via a pressure transducer with force/stroke monitored presses

Round ram locked against rotation with TDC switch (74/76) or position measuring system (374/376) on the anti-rotational guide rod.

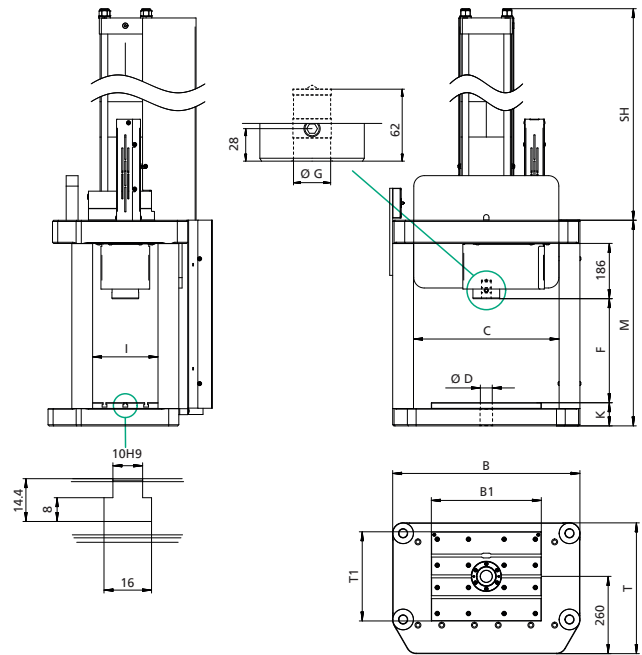

Rapid approach stroke

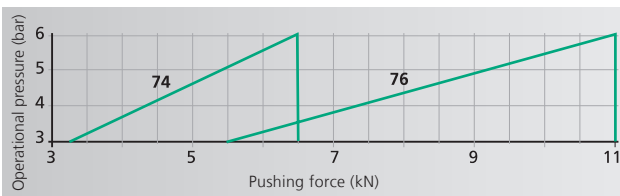

Power stroke

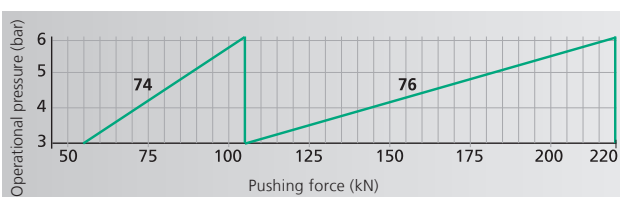

Return stroke

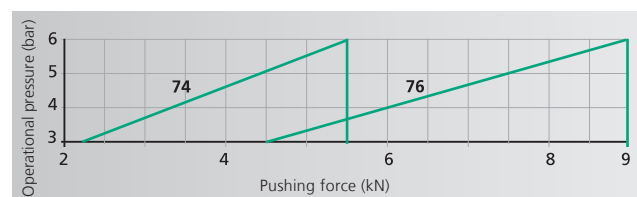

From 100 kN to 220 kN in power stroke

Press Type			74		76	
Total stroke – power stroke ¹⁾		mm	100–12	150–22	100 – 12	150 – 20
Nominal force at 6 bar		kN	100	100	220	220
Ram bore	G	Ø mm	25 ^{H7}	25 ^{H7}	32 ^{H7}	32 ^{H7}
External ram dimensions		Ø mm	90	90	90	90
Working height ²⁾	F		350	350	350	350
Press head height	SH		919	1181	1157	1400
Frame height	K	mm	78	78	78	78
H-frame height	M	mm	692	692	692	692
Floor space required	B x T	mm	630 x 440	630 x 440	630 x 440	630 x 440
Table size	B x T	mm	370 x 300	370 x 300	370 x 300	370 x 300
Table bore	D	Ø mm	40 ^{H7}	40 ^{H7}	40 ^{H7}	40 ^{H7}
Clearance	C	mm	490	490	490	490
Clearance side	I	mm	220	220	220	220
Weight (standard)		approx. kg	550	605	610	665

Press Type			374		376	
Total stroke – power stroke ¹⁾		mm	100–12	150 – 22	100–12	150 – 20
Nennkraft bei 6 bar		kN	100	100	220	
Process data acquisition – stroke		µm/inc	5	5	5	5
– force		N/inc	32	32	62,5	62,5
Ram bore	G	Ø mm	25 ^{H7}	25 ^{H7}	32 ^{H7}	32 ^{H7}
External ram dimensions		Ø mm	90	90	90	90
Working height ²⁾	F		350	350	350	350
Press head height	SH		919	1181	1157	1400
Frame height	K	mm	78	78	78	78
H-frame height	M	mm	692	692	692	692
Floor space required	B x T	mm	630 x 440	630 x 440	630 x 440	630 x 440
Table size	B1 x T1	mm	370 x 300	370 x 300	370 x 300	370 x 300
Table bore	D	Ø mm	40 ^{H7}	40 ^{H7}	40 ^{H7}	40 ^{H7}
Clearance	C	mm	490	490	490	490
Clearance side	I	mm	220	220	220	220
Weight (standard)		approx. kg	550	605	610	665

Options

- ¹⁾ Total stroke / power stroke options on request
- ²⁾ Typical values; can vary ±3 mm due to casting and production tolerances

Accessories



High-pressure switch

After switching from rapid approach stroke to power stroke, the oil pressure rises in the hydraulic chamber of the cylinder. The high-pressure switch can be adjusted to reach a determined press force through the output generated by the oil pressure in the press.



Adjustment bushing for SCHMIDT® HydroPneumatic-Press No. 74 and 76

For a simplistic adjustment of the working height with a setting range of 100 mm. This greatly reduces the need for spacers to accommodate different working heights during setup changes.



Oil pump

For an air-free refilling of the SCHMIDT® HydroPneumatic-Press with hydraulic oil, including 1 liter Hydraulic oil.

SCHMIDT® Cylinder Units

For flexible use

SCHMIDT® Double-acting cylinder units are useful components for the construction of special machines. They can be mounted independently and are equipped with a magnet kit for detecting the corresponding end position using a cylinder switch. Direct

acting air provided as flange or side-mount models and toggle or hydropneumatic type as side mount models, achieving forces up to 100 kN.



Press head (side-mount) model



Flange model



Technical Data	SCHMIDT® Cylinder Units	
Typ No.	Press head model	Flange model
20 - 29	•	•
32 - 36	•	
61 - 68	•	• (not for No. 61, 62, 65)
323 - 368	•	•

For the performance data, please refer to the chapters **SCHMIDT® PneumaticPress** and **SCHMIDT® HydroPneumaticPress**, optional with force/stroke monitoring.

Order indications

Key for design options

<p>Cylinder unit / stroke / design</p> <p>Order example head 65 - 50 - 6</p> <p>Press no. <input type="text"/></p> <p>Total stroke <input type="text"/></p> <p>Power stroke <input type="text"/></p> <p>= SCHMIDT® Cylinder Unit No. 65 with total stroke 50 mm and power stroke 6 mm as press head model</p>	<p>Cylinder unit / stroke / design</p> <p>Order example 20 - 50 - FL</p> <p>Press no. <input type="text"/></p> <p>Stroke <input type="text"/></p> <p>Model <input type="text"/></p> <p>= SCHMIDT® Cylinder Unit no. 20 with stroke 50 mm as flange model</p>
--	---