

Safety Concepts Single Workstations Customer-Specific Solutions

SCHMIDT[®] SmartGuard and SCHMIDT[®] SmartGate,
light curtain and two-hand safety technology



SCHMIDT® Single Workstations

Ergonomics with certified safety technology

SCHMIDT® workstations are supplied ready to use with certified safety technology and corresponding operating elements. Depending on customer requirements, workstations can be equipped with the following safety elements:

- SCHMIDT® SmartGuard protection cover
- SCHMIDT® SmartGate protective housing with automatic doors
- light curtain
- two-hand safety

The delivery includes:

- Module SCHMIDT® presses mounted on stand or pedestal
- SCHMIDT® PressControl 75 (in two-hand release and light curtain versions), 700 or PressControl 7000 with pendant arm system
- Press base PU 20 / PU 40 in rigid or height-adjustable design, depending on the safety concept optional or as standard

All systems are EC type-approved!

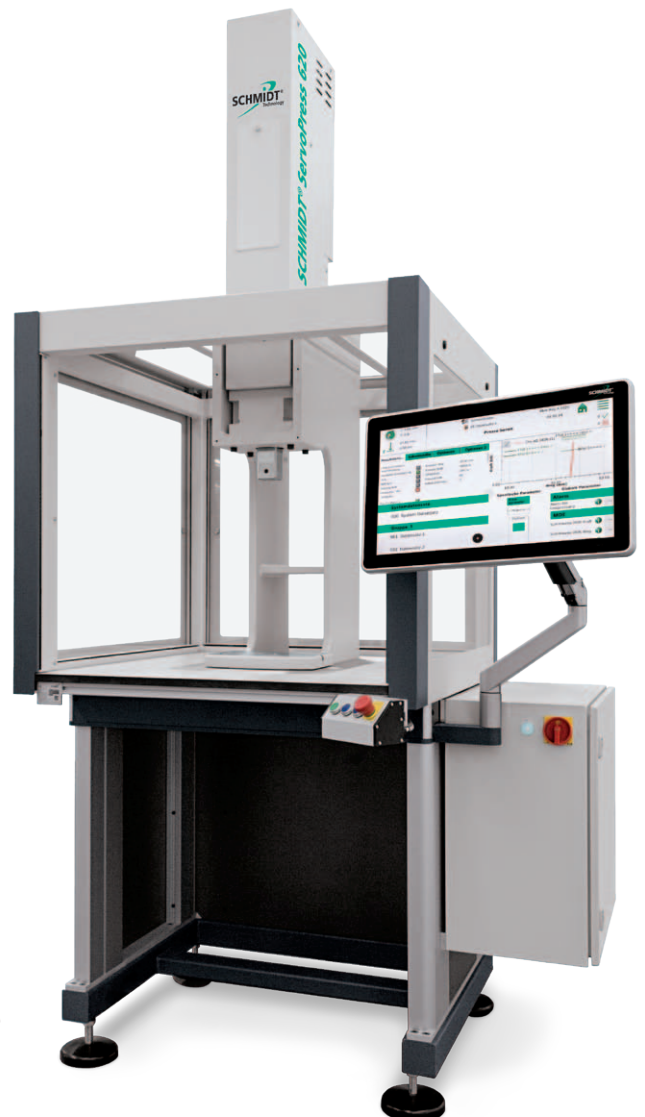
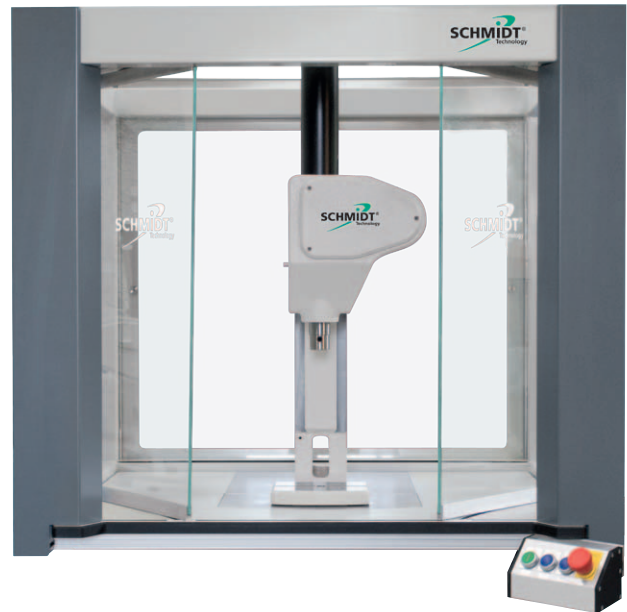

SCHMIDT® SmartGate

Shorter process cycles and increased safety standards

SmartGate is a protective enclosure with automatic doors. The access to the process area is via two transparent, horizontally guided door elements. Key benefits of SmartGate over other safety concepts, such as light curtain or two-hand systems, are the significant increase in ergonomics and workflow efficiency through reduction of required safety margins and the excellent accessibility of the process space.

SmartGate sets new standards in the field of safety by completely closing off the process area, completely eliminating unintentional third-party intervention or fragmentation. SmartGate is particularly suitable for processes with the risk of splintering due to protection against flying parts or spalling.

When designing SmartGate, we ensured that all surfaces are as easy to clean as possible and that there are no areas where residues or particles can accumulate. High demands on purity and cleanliness, as they occur, for example, in applications in medical technology can therefore be easily met.

SmartGate		
Max. opening width	720	mm
Variable speed	50 – 350	mm/s
Typical opening time	2.2 s	
Typical closing time	1.8 s	
Noise emission	< 60	dB(A)
Cell size 1	1010 x 883	mm
Cell size 2	1010 x 1049	mm
Protective door	laminated safety glass (VSG)	
Safety category	Plexiglass	



Characteristics

- Protection of the working area from unintentional intervention
- Splinter protection from chipping of parts
- Visible working space
- Optimization of the safety distances to the complete danger area
- Consideration of quality assurance requirements (NIO behaviour)
- Cycle time and process optimization through programmable opening and closing speed (<2 s)
- Very high energy efficiency due to linear motor drive
- Type approved

SCHMIDT® Safety Technology

Smart Safety Concept for Servo and Torque presses

The transparent protective housing entirely encloses the working area during the press process. It thus prevents the user and a third person from getting their hands into the danger area and efficiently protects against the particles or splinters that may be ejected. The distances to the working zone are minimized which considerably improves the ergonomics and the efficiency of the workstations. The high dynamics of the protective housing with numerical control and its variable positioning capability and traversing velocity optimize the process cycle. The smart construction prevents any trap points in the enclosure.

SCHMIDT® SmartGuard is a protective shield for TorquePress 520, TorquePress 560 and ServoPress 605 to 620.

SmartGuard	type	SP 605	SP 616	SP 617	SP 620	TP 520
Variable opening stroke	mm	280	350	410	500	390
Speed opening	mm/s	200 - 1000				
Speed closing	mm/s	200 - 500				
Drive	type	linear motor				
Deep	mm	434	485	573	644	599
Wide	mm	232	286	312	359	343
Height	mm	1018	1111	1440	1840	1640
Material guard	PC	antistatic / transparent				
Electr. safety lock		Ple				

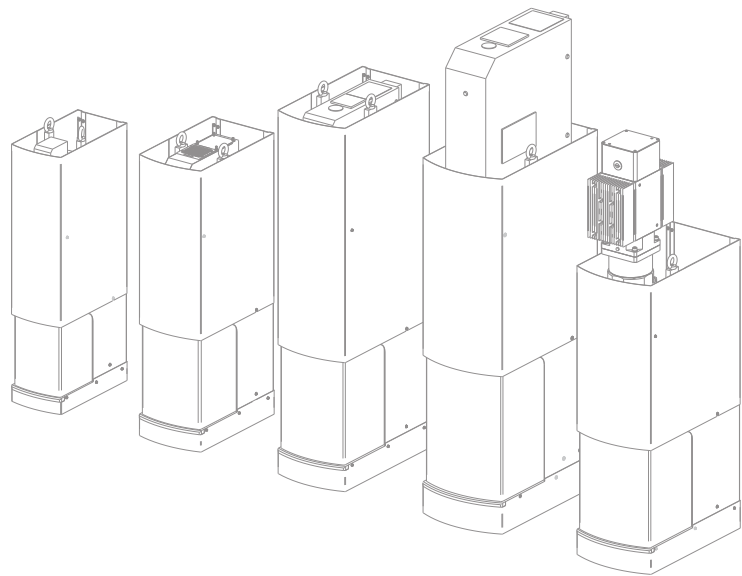

Characteristics

- Protection of the working area from unintentional intervention
- Splinter protection from chipping of parts
- Visible working space
- Optimization of the safety distances to the complete danger area
- Consideration of quality assurance requirements (NIO consideration)
- Cycle time and process optimization through programmable opening and closing speed (<2 s) and the opening height
- Very high energy efficiency due to linear motor drive
- Type approved
- ESD version possible

Classic Safety Concepts

Light curtain with guarding

The light curtain control provides optimum safety to the user. The process area is protected with polycarbonate windows against contact. A light curtain protects the access to the hazard area on the side of insertion. The working process is immediately interrupted and the dangerous motion of the press is stopped. The cycle can be continued automatically after leaving the danger area. In combination with **SCHMIDT® ServoPress**, the light curtain control is the basic version. The press can be activated via the light curtain. Depending on the application, it can be selected between 1-cycle and 2-cycle activation.



Two-hand safety technology

In basic design, **SCHMIDT® PneumaticPress**, **SCHMIDT® Hydro-PneumaticPress** as well as **SCHMIDT® ElectricPress** are operated with **two-hand safety technology**. The user must keep both switches in the activated position. If one switch is released ahead of time, the press stroke is interrupted. This applies to all positions above the automatic stroke takeover that is started from the point where the dangerous closing movement is finished. From the stroke takeover, the stroke is continued automatically.



SCHMIDT® Press Bases

Ergonomic in focus

SCHMIDT® Press Base PU 20 and PU 40 for a safe and vibration-proof installation of all SCHMIDT® Press Systems.

Both press bases are available in two versions:

- Fixed columns with height adjustable in 10 mm (0.4") increments from 780 to 1080 mm (30.7" – 42.5")
- Infinitely variable motorized height adjustment from 725 to 1075 mm (28.5" – 42.3")

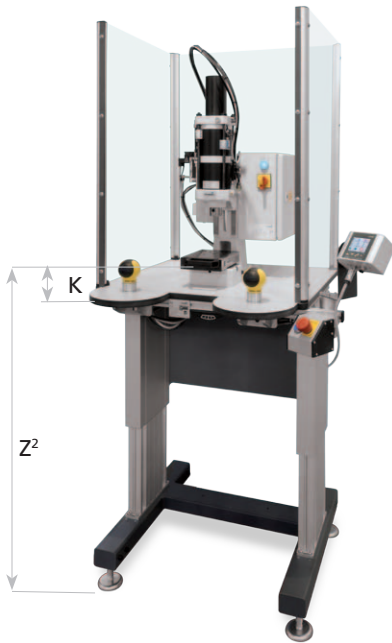

PU 20 with two variable columns

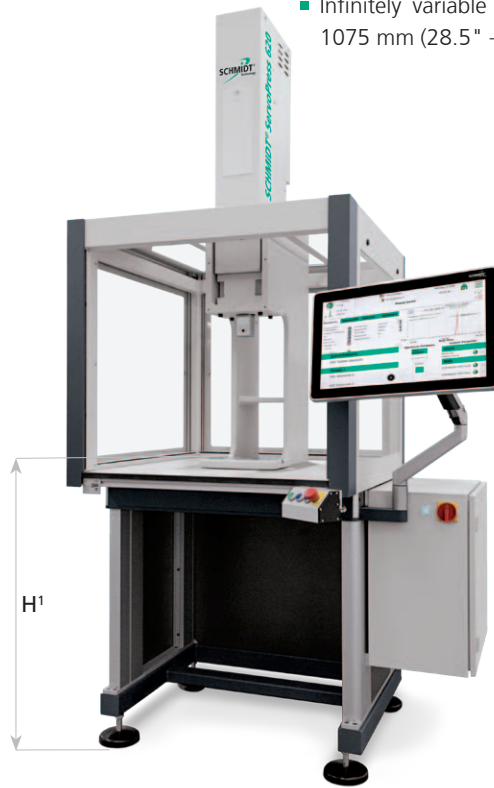

PU 40 with four fixed columns



PU 40 with four variable columns

Technical Data			PU 20 (2 columns)	PU 40 (4 columns)
Fixed columns	H	individually	780 – 1200 mm	780 – 1200 mm
Motorized variable columns	Z	stepless	725 – 1075 mm	725 – 1075 mm
Lifting capacity		kg	600	1200
Width x depth			on request	on request
Foot rest			–	✓

¹⁾ Height H measured from floor space to press table top

²⁾ Fixing dimension Z stand on PU20, resulting height of the press table depends on frame type (see dimension K in the respective press chapters). Example: frame type 3 for press No. 25 K = 60 mm, PU20 (725 mm to 1075 mm) and press table height 60 mm results in total press table infinitely adjustable from 785 mm to 1135 mm

SCHMIDT® Four-column Gantry

SCHMIDT® Four-column gantries used in manual workstations, and automated assembly lines, are suitable for all SCHMIDT® Presses with extraordinary requirements in all working area.

In order to consider the large number of applications and cases, the design is adapted specifically to your requirements. All individual requirements can be taken into account. Short delivery times are realized because of in-house production. Contact us with dimensions (see table), and we can supply you with a proposal.

Characteristics base plate

- Coated: RAL 7035 (light-grey)
- Cross T-slot 45° 14^{H7}
- Central bore 40^{H7}, other bores on request

Characteristics cover plate

- Coated: RAL 7035 (light-grey)
- Connection drill pattern for the required press
- Chromium-plated columns

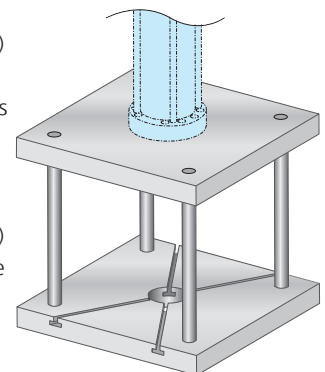

SCHMIDT® Slide Tables

For efficient production

SCHMIDT® Slide Tables are specially designed for the high forces of press systems and where a position requires high precision against an adjustable stop. It is an economic solution for tall parts and for placement of parts outside of the danger area. They can be mounted, depending on the type, both in longitudinal and lateral positions, and can be adapted for automated processes.

Characteristics

- Force closure due to unique anvil system
- Backlash-free guide systems for consistent smooth running over the entire stroke
- Operator safety due to covering of danger points (no pinch points)
- High reliability due to protection against particle ingress
- Dynamic end-position cushioning prevents hard impacts
- Triggering of the press stroke via adjustable position sensors



SCHMIDT® Slide Table
ST 100M longitudinal with handle



ST 100M / ST 100P

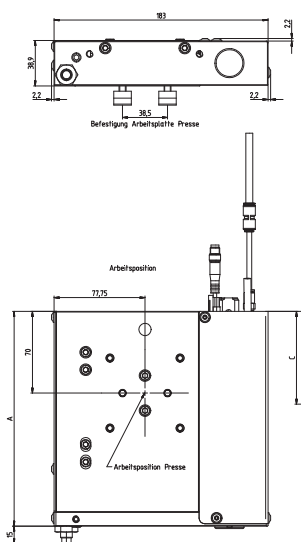

ST 150M / ST 150P

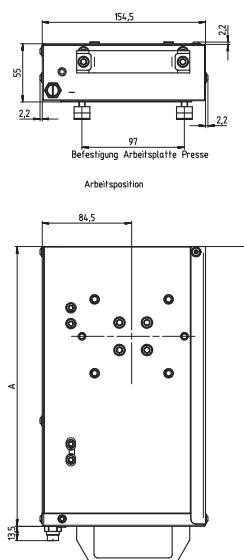

SCHMIDT® Slide Table
ST 100M cross mounting with adapter plate for fastening on the fixture mounting plat



Type		ST 100M	ST 100P	ST 150M	ST 150P
Pressure load	kN	100	100	150	150
Max. stroke V1	mm	79	80	129	130
Max. stroke V2	mm	159	160	199	200
Repeatability working position	mm	±0.01	±0.01	±0.01	±0.01
Repeatability loading position	mm	±0,2	±0,01	±0,2	±0,01
Dimensions B/H/T V1	mm	142 / 39 / 220	188 / 39 / 211	159 / 55 / 301	159 / 55 / 279
Dimensions B/H/T V2	mm	142 / 39 / 300	188 / 39 / 291	212 / 55 / 271	212 / 55 / 349
Weight V1	kg	3.6	4.2	10.8	12.7
Weight V2	kg	6.9	7.6	11.8	14.1
Max. tool weight	kg	10	10	10	10
Operating mode		manual	pneumatic	manual	pneumatic

SCHMIDT® Customer-Specific Solutions

Standard 'out of the catalog' products, customized or complete turn key solutions. **SCHMIDT Technology** is an invaluable source for your assembly needs, with the center point being a press. We welcome the opportunity to evaluate your application, perform feasibility studies, process sample parts to determine process capability from a control, as well as monitoring standpoint.

We can take your applications from process development and manufacturing of prototype tooling to provide you with custom designed, turn-key solutions.

SCHMIDT® engineers and sales force have gained a wealth of experience while working on a wide array of applications.

SCHMIDT Technology products are suitable for a broad variety of industries and can be tailored to the specific requirements and challenges that applications present, from very basic and simple pressing operations to intelligent, precise and complex processes, combined with monitoring.

The ever rising need to log and exchange process data with third party systems can easily be addressed by the various ways our control systems can be interfaced.

Your need is our challenge. We look forward to the opportunity to be of service.



SCHMIDT® ElectricPress 43/343 Automation

Integrates easily and quickly into an automated system; ideal for new design concepts, integration or as a replacement in an existing production line.



SCHMIDT® Customer-Specific Solutions



"Compliant Pin" application

SCHMIDT® ServoPress Systems are the ideal tool for press-fit applications. Their integrated process data and closed-loop force control is perfect for the assembly and disassembly of electronic components. In contrast to soldering, press-fit contacts on a circuit board requires precisely defined and closely monitored assembly processes at very slow speeds. A **SCHMIDT® Press** can be the solution.

All **SCHMIDT® Press Types** can be integrated in a rotary indexing system. Depending on the requirements of the customer, an individual design is planned.

Hybrid Assembly Cell Configuration with

- a monitored PneumaticPress
- a monitored ServoPress
- a conventional HydroPneumaticPress

A single **SCHMIDT® PressControl 7000 RT** can control all of these presses as well as an indexing table. It acquires all stroke/force process data, which can then be transmitted to the **SCHMIDT® DataBase** software for storage and analysis.



SCHMIDT® Support

Close to the customer thanks to a perfect service

SCHMIDT® DemoBus

Our press technology will come to your premises. The **SCHMIDT® DemoBus** contains a selection of fully functional presses and accessories.

- See the innovative news and trends
- Get a wide overview over our products
- Do not lose time and save travel costs
- Discuss your assembly applications with our experts
- Conduct trials (by prior arrangements)



SCHMIDT® CompetenceCenter

We have a large number of presses and press systems in our exhibition and testing area at your disposal. Visitors are welcome to our Competence Center to discuss at first hand their specific requirements with our team of experts, who will be pleased to conduct trials on their tools and offer advice and best solutions for all applications.



SCHMIDT® TrainingCenter

Our training packages prepare the participants fully in theory and practice for their daily work with **SCHMIDT® Press Systems**, by offering comprehensive user training courses and seminars on complex technological products. These training courses deal with the handling of the products as well as the correct use of the control and process software. **SCHMIDT Technology** stands for high quality products and their efficient use on site.



SCHMIDT® Services portfolio

We support you either on site and from in-house

In order to meet the high quality standards of modern production, to comply with legal requirements periodic calibrations and safety tests of the press systems according to DIN ISO 9000, safety measures are required.

SCHMIDT Technology assists you by means of a strong service package in meeting these requirements.

SCHMIDT® Calibration
for force-monitored press systems

- SCHMIDT® PressControl**
- Checking the measurement system
 - Calibration
 - Issue of a test certificate incl. test report
 - Calibration sticker on the machine

SCHMIDT® SafetyCheck
for all **SCHMIDT® PressSystems** with type approval

- Test according to the relevant standards
- Measurement and test of the two-hand switching
- Follow-up measurement
- Functional safety check
- General functional check
- Issue of a test report
- Test sticker on the machine

For Light Curtain Systems

- Additional test according to the relevant standards



Telephone support

Our service is available Monday through Friday from 7:30 am to 4:30 pm (GMT +1). Emergency telephone assistance and a reaction time within 24 hours are our standard.

Service Center world wide

Head Quarter

SCHMIDT Technology GmbH

Feldbergstr. 1 · 78112 St. Georgen im Schwarzwald
Germany

support@schmidttechnology.de · Phone +49 7724 899 300

Service Center US – 24/7 Hotline

SCHMIDT Technology Corp.

280 Executive Drive
Cranberry Township, PA 16066
USA

service@schmidtpresses.com · Phone +1 (724) 814-5241

Service Center Asia

NIXMA TECHNOLOGY CO., LTD.

9/79 Moo 5, Phaholyothin Road, T. Klong Nueng,
A. Klong Luang, Pathum Thani 12120
Thailand

www.schmidt-servicecenter.asia · Phone +66 2902 2394

Service Center UK

APS Ltd

Unit 21, Easter Park · Benyon Road
Reading · Berkshire, RG7 2PQ
UK

vincent.small@aps-ltd.co.uk · Phone +44 777 358 9201

Service Center Hungary, Bulgaria, Romania

Eckerle Industrie Kft.

Dózsa György út 44 · 6200 Kiskörös
Hungary

info@hu.eckerle-gruppe.com · Phone + 36 (0) 78 / 511 400